

Tektronix®
COMMITTED TO EXCELLENCE

**DM 502A
AUTORANGING
DIGITAL
MULTIMETER**

INSTRUCTION MANUAL

Tektronix, Inc.
P.O. Box 500
Beaverton, Oregon 97077

Serial Number _____

WARRANTY

Tektronix warrants that this product is free from defects in materials and workmanship. The warranty period is one (1) year from the date of shipment. Tektronix will, at its option, repair or replace the product if Tektronix determines it is defective within the warranty period and if it is returned, freight prepaid, to a service center designated by Tektronix.

Tektronix is not obligated to furnish service under this warranty

- to repair damage resulting from attempts by personnel other than Tektronix representatives to install, repair, or service the product;
- to repair damage resulting from improper use or from connecting the product to incompatible equipment;
- if personnel other than Tektronix representatives modify the hardware or software.

There is no implied warranty of fitness for a particular purpose. Tektronix is not liable for consequential damages.

Copyright © 1979 Tektronix, Inc. All rights reserved. Contents of this publication may not be reproduced in any form without the written permission of Tektronix, Inc.

Products of Tektronix, Inc. and its subsidiaries are covered by U.S. and foreign patents and/or pending patents.

TEKTRONIX, TEK, SCOPE-MOBILE, and  are registered trademarks of Tektronix, Inc.

Printed in U.S.A. Specification and price change privileges are reserved.

GARANTIE

Tektronix gibt dem Käufer auf dieses Gerät, daß sich in einwandfreiem Zustand befindet, eine einjährige Garantie bei sachgemäßer Behandlung. Die Garantiezeit beginnt mit dem Tag der Verschiffung. Tektronix repariert oder ersetzt dieses Gerät, wenn eine einwandfreie Fehlerbestimmung durch Tektronix innerhalb der Garantiezeit vorliegt und es frachtfrei an das nächste Tektronix-Service-Center geschickt wird.

Es gibt keine Garantie, daß sich das Gerät für einen ganz bestimmten Zweck eignet. Tektronix kann nicht haftbar gemacht werden für Folgeschäden.

Copyright © 1979 durch Tektronix, Inc. Alle Rechte vorbehalten. Der Inhalt dieser Publikation darf ohne Genehmigung von Tektronix, Inc. nicht wiedergegeben werden.

Produkte von Tektronix, Inc. und seinen Tochtergesellschaften sind durch US- und Auslandspatente und/oder schwebenden Patente abgedeckt.

TEKTRONIX, TEK, SCOPE-MOBILE und  sind geschützte Warenzeichen von Tektronix, Inc.

Gedruckt in U.S.A. Spezifikations- und Preisänderungen bleiben vorbehalten.

GARANTIE

Les appareils TEKTRONIX, en condition normale d'utilisation, sont garantis à l'acheteur d'origine contre tout défaut de matière

Les appareils TEKTRONIX, en condition normale d'utilisation, sont garantis à l'acheteur d'origine contre tout défaut de matière ou vice de fabrication, pour une durée d'une année, à compter du jour de livraison. Durant cette période, les pièces défectueuses sont remplacées, TEKTRONIX se réservant la décision de procéder soit à la réparation soit au remplacement du produit. En cas de retour du matériel à un centre Tektronix, le transport aller est à la charge du client.

Il n'y a pas de garantie implicite de l'adaptation à une application particulière. Tektronix n'est pas responsable des dommages résultants.

Copyright © 1979 TEKTRONIX INC. Tous droits réservés. Le contenu de ce manuel ne peut être reproduit sous quelque forme que ce soit sans l'accord de Tektronix Inc.

Tous les produits TEKTRONIX INC sont brevetés US et étranger et les logotypes TEKTRONIX, TEK, SCOPE MOBILE,  sont déposés.

Imprimé aux U.S.A. TEKTRONIX se réserve le droit de modifier caractéristiques et prix dans le cadre de développements technologiques.

TABLE OF CONTENTS

	Page		Page
LIST OF ILLUSTRATIONS	iii	French Version	
LIST OF TABLES	iv	UTILISATION—FRANCAIS	
OPERATOR SAFETY SUMMARY	v	Chapitre 2 INSTRUCTIONS D'UTILISATION	
SERVICE SAFETY SUMMARY	vii		
Section 1 SPECIFICATION	1-1	Description de l'appareil	2-1
Instrument Description	1-1	Accessoires	2-1
Accessories	1-1	Conditions de vérification des performances	2-1
Performance Conditions	1-1	Instructions d'installation	2-1
Electrical Characteristics	1-1	Commandes, bornes d'entrées et voyants lumineux	2-2
Environmental Characteristics ...	1-8	Connexions d'entrée	2-2
TM 500 Systems Environmental Specifications	1-9	Réalisation des mesures	2-4
Physical Characteristics	1-9	Mesures de tension continue	2-4
		Mesures de tension alternative ...	2-4
		Mesures de niveaux (décibels) ...	2-4
		Mesures de résistance	2-5
		Mesures de courant	2-5
		Mesures de température	2-5
		Instructions de réemballage pour expédition	2-5
Section 2 OPERATING INSTRUCTIONS			
English Version		German Version	
Installation and Removal	2-1	Kapitel 2 BEDIENUNGSEINFÜHRUNG	
Controls, Connectors, and Indicators	2-2	Einbau-Anleitung	2-1
Input Connections	2-4	Vorbereitung für Gebrauch	2-1
Making Measurements	2-4	Verpackungshinweise	2-2
DC Voltage Measurements	2-4	Bedienungselemente und Anschlüsse	2-2
AC Voltage Measurements	2-4	Bedienungsanleitung	2-3
Decibel Measurements	2-4	Allgemeine Bedienungsinformation	2-3
Resistance Measurements	2-4	Ausgangsverbindungen	2-4
Current Measurements	2-4	Frequenzwahl	2-6
Temperature Measurements ...	2-5	Ausgangspegelwahl	2-6
Repackaging Information	2-5	Intermodulation Test-Signal	2-6
		Rückseitige Interface-Signale ...	2-7





TABLE OF CONTENTS (cont)

Japanese Version	Page
取扱説明	
第2章 取扱説明	
取付および取はずし方法.....	2-1
コントロール、コネクタおよびインジケータ ..	2-2
入力との接続.....	2-4
機能説明.....	2-4
D C 電圧測定.....	2-4
A C 電圧測定.....	2-4
デシベル測定.....	2-4
抵抗測定.....	2-4
電流測定.....	2-4
温度測定.....	2-5
梱包方法.....	2-5
WARNING	
<p><i>THE FOLLOWING SERVICING INSTRUCTIONS ARE FOR USE BY QUALIFIED PERSONNEL ONLY. TO AVOID PERSONAL INJURY, DO NOT PERFORM ANY SERVICING OTHER THAN THAT CONTAINED IN OPERATING INSTRUCTIONS UNLESS YOU ARE QUALIFIED TO DO SO.</i></p>	
Section 3	THEORY OF OPERATION 3-1
	Introduction 3-1
	Voltage and dB Input Circuitry . . . 3-1
	Ohms Converter 3-1
	Temperature Measurement Circuitry 3-1
	Current Measurement Circuitry . . . 3-3
	Analog-to-Digital Converter 3-3
	Auto Zero Interval 3-3
	Measurement Interval 3-3
	Decimal Point Logic 3-5
	Auto Ranging Circuitry 3-6
	Relay Switching Circuitry 3-6
	dB Offset Current Source 3-7
	Power Supplies 3-7
Section 4	CALIBRATION 4-1
	Performance Check 4-1
	Introduction 4-1
	Test Equipment Required 4-1
	Rear Interface Accuracy Checks 4-10
	Adjustment Procedure 4-11
	Introduction 4-12
	Calibration Interval 4-12
	Services Available 4-12
	Test Equipment Required 4-12
	Preparation 4-12
Section 5	MAINTENANCE 5-1
	Preventive Maintenance 5-1
	Corrective Maintenance 5-1
	Circuit Board Removal 5-1
	Heat Sink Removal and Replacement 5-1
	Obtaining Replacement Parts . . . 5-1
	Ordering Parts 5-1
	Troubleshooting Aids 5-1
	Static-Sensitive Components 5-1
	Test Equipment 5-2
Section 6	OPTIONS 6-1
	Standard Instrument 6-1
	Option 2 Instrument 6-1
Section 7	REPLACEABLE ELECTRICAL PARTS 7-1
Section 8	DIAGRAMS AND ILLUSTRATIONS Troubleshooting Flowcharts Schematic Diagrams Parts Location Grids and Reference Tables
Section 9	REPLACEABLE MECHANICAL PARTS 9-1
	Exploded View Accessories
CHANGE INFORMATION	

LIST OF ILLUSTRATIONS

Figure		Page
2-1	Installation and Removal	2-1
2-2	Front Panel Controls and Connectors	2-3
3-1	Auto Zero and Measurement Interval Timing Sequences	3-4
3-2	Data Output Format From U1311 for a Display of 1492	3-5
8-1	DM 502A Block Diagram	
8-2	Analog-to-Digital Block Diagram	
8-3	Adjustment Locations (Main Board)	
8-4	Adjustment Locations (Analog Board)	
	Troubleshooting Flowcharts	
8-5	Power Supply	
8-6	DC Volts	
8-7	DC Current	
8-8	Ohms	
8-9	AC Volts	
8-10	AC Current	
8-11	Decibels (dB)	
8-12	Temperature	
8-13	Auto Range	
	Parts Location Grids	
8-14	Analog Board (A13)	
8-15	Main Board (A15)	
8-16	Display Board (A11)	

LIST OF TABLES

Table		Page
1-1	DC VOLTMETER	1-1
1-2	AC VOLTMETER (TRUE RMS)	1-2
1-3	DECIBELS (dB)—TRUE RMS	1-3
1-4	OHMMETER	1-5
1-5	DC AMMETER	1-6
1-6	AC AMMETER	1-6
1-7	TEMPERATURE	1-7
1-8	MISCELLANEOUS	1-7
1-9	ENVIRONMENTAL CHARACTERISTICS	1-8
1-10	TM 500 SYSTEM ENVIRONMENTAL SPECIFICATIONS	1-9
1-11	PHYSICAL CHARACTERISTICS	1-9
3-1	RELAY AND ATTENUATOR (Q1472) LOGIC	3-2
4-1	TEST EQUIPMENT	4-1
4-2	FRONT PANEL DC VOLTAGE LIMITS	4-3
4-3	FRONT PANEL AC VOLTAGE LIMITS	4-4
4-4	FRONT PANEL dB LIMITS	4-5
4-5	FRONT PANEL RESISTANCE LIMITS	4-6
4-6	FRONT PANEL DC CURRENT LIMITS	4-7
4-7	FRONT PANEL AC CURRENT LIMITS	4-8
4-8	FRONT PANEL TEMPERATURE LIMITS	4-9
4-9	REAR INTERFACE DC LIMITS	4-10
4-10	REAR INTERFACE AC LIMITS	4-11
4-11	REAR INTERFACE RESISTANCE LIMITS	4-11
5-1	RELATIVE SUSCEPTIBILITY TO STATIC DISCHARGE DAMAGE	5-2
8-1	REAR INTERFACE CONNECTOR ASSIGNMENTS	
	COMPONENT REFERENCE CHARTS	
8-2	INPUT CIRCUITRY 	
8-3	A/D CONVERTER, dB SCALING, PWR SUPPLY 	
8-4	DISPLAY & LOGIC CIRCUITRY 	
8-5	RANGE LOGIC 	

OPERATORS SAFETY SUMMARY

The general safety information in this part of the summary is for both operating and servicing personnel. Specific warnings and cautions will be found throughout the manual where they apply, but may not appear in this summary.

TERMS

In This Manual

CAUTION statements identify conditions or practices that could result in damage to the equipment or other property.

WARNING statements identify conditions or practices that could result in personal injury or loss of life.

As Marked on Equipment

CAUTION indicates a personal injury hazard not immediately accessible as one reads the marking, or a hazard to property including the equipment itself.

DANGER indicates a personal injury hazard immediately accessible as one reads the marking.

SYMBOLS

In This Manual



This symbol indicates where applicable cautionary or other information is to be found.

As Marked on Equipment



DANGER — High voltage.



Protective ground (earth) terminal.



ATTENTION — refer to manual.

Power Source

This product is intended to operate in a power module connected to a power source that will not apply more than 250 volts rms between the supply conductors or between either supply conductor and ground. A protective ground connection by way of the grounding conductor in the power cord is essential for safe operation.

Grounding the Product

When installed in the power module, this product is grounded through the grounding conductor of the power cord. To avoid electrical shock, plug the power cord into a properly wired receptacle before connecting to the product input or output terminals. Upon loss of the protective ground connection, all accessible conductive parts (including knobs and controls that may appear to be insulating) can render an electric shock.

Use the Proper Fuse

To avoid fire hazard, use only the fuse specified in the parts list for your product, and which is identical in type, voltage rating, and current rating.

Refer fuse replacement to qualified service personnel.

Do Not Operate In Explosive Atmospheres

To avoid explosion, do not operate this product in an atmosphere of explosive gases unless it has been specifically certified for such operation.

Do Not Remove Covers or Panels

To avoid personal injury, do not remove the product covers or panels. Do not operate the product without the covers and panels properly installed.

Do Not Operate Without Covers

To avoid personal injury, do not operate this product without covers or panels installed. Do not apply power to the plug-in via a plug-in extender.

SERVICING SAFETY SUMMARY

FOR QUALIFIED SERVICE PERSONNEL ONLY

Refer also to the preceding Operators Safety Summary.

Do Not Service Alone

Do not perform internal service or adjustment of this product unless another person capable of rendering first aid and resuscitation is present.

Use Care When Servicing With Power On

Dangerous voltages exist at several points in this product. To avoid personal injury, do not touch exposed connections and components while power is on.

Disconnect power before removing protective panels, soldering, or replacing components.

Power Source

This product is intended to operate from a power source that will not apply more than 250 volts rms between the supply conductors or between either supply conductor and ground. A protective ground connection by way of the grounding conductor in the power cord is essential for safe operation.

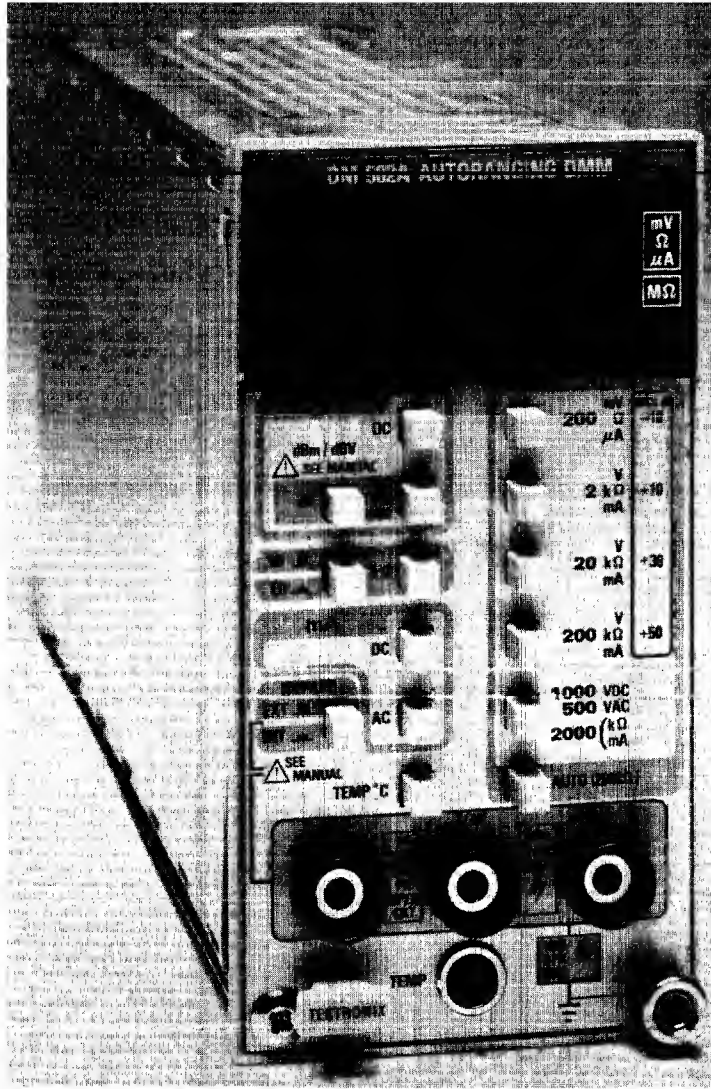

2693-1

DM 502A Autoranging Digital Multimeter.

SPECIFICATION

Instrument Description

The DM 502A Digital Multimeter measures dc and ac voltage and current, dBm, dBV, resistance, and temperature. The ac functions are true rms responding. The ranges for dc voltage, ac voltage, dBm, dBV, and resistance are automatically or manually selected as desired. The current and temperature ranges are manually selected.

Rear interface connector input is pushbutton selected from the front panel. Readout in dBm or dBV is chosen by an internal jumper. The unit is shipped with the internal jumper in the dBm position.

The readout is a 3 1/2 digit display using seven segment LED. The decimal point is automatically positioned depending on the operating range of the instrument. Polarity indication is automatic.

Accessories

Standard accessories include this instruction manual, a set of test leads, and the TEKTRONIX P6601 temperature probe. The P6601 temperature probe and temperature measurement capabilities are deleted for Option 2 instruments.

Performance Conditions

The electrical characteristics are valid only if the DM 502A has been calibrated at an ambient temperature between +21°C and +25°C and is operating at an ambient temperature between 0°C and +50°C.

Items listed in the Performance Requirements column of the Electrical Characteristics are verified by completing the Performance Check in the Calibration section of this manual. Items listed in the Supplemental Information column are not verified in this manual. They are either explanatory notes or performance characteristics for which no limits are specified.

ELECTRICAL CHARACTERISTICS

Table 1-1
DC VOLTMETER

Characteristics	Performance Requirements	Supplemental Information
Accuracy for 200 mV, 2 V, 20 V, 200 V, and 1000 V ranges (Front Panel and Rear Interface)		Automatic or manual ranging.
+18°C to +28°C 200 mV to 200 V ranges 1000 V range	$\pm(0.1\% \text{ of reading} + 0.05\% \text{ of full scale})$ $\pm(0.1\% \text{ of reading} + 0.1\% \text{ of full scale})$	Maximum input for rear interface is 200 V peak.
0°C to +18°C, +28°C to +50°C 200 mV to 200 V ranges 1000 V range	$\pm(0.2\% \text{ of reading} + 0.1\% \text{ of full scale})$ $\pm(0.2\% \text{ of reading} + 0.2\% \text{ of full scale})$	Maximum input for rear interface is 200 V peak.
Common Mode Rejection Ratio	$\geq 100 \text{ dB at dc.}$ $\geq 80 \text{ dB at } 50 \text{ to } 60 \text{ Hz } \pm 0.2 \text{ Hz.}$	Verified with a 1 k Ω unbalance in series with LOW terminal. (Internal clock frequency must be 20.48 kHz $\pm 1\%$.)
Normal Mode Rejection Ratio	$\geq 50 \text{ dB at } 50 \text{ or } 60 \text{ Hz } \pm 0.2 \text{ Hz.}$	(Internal clock frequency must be 20.48 kHz $\pm 1\%$.)

Table 1-1 (cont)

Characteristics	Performance Requirements	Supplemental Information
Maximum Resolution		100 μ V.
Step Response Time		<1 second within any range. Add 1.5 seconds for each range change in the AUTO mode.
Input Resistance		10 M Ω \pm 0.5%.
Input Terminals		Front panel (EXT) or rear interface (INT). Switch selectable.
Maximum Input Voltage		
Front Panel Terminals		
VOLTS/ Ω to LOW		1000 V peak.
VOLTS/ Ω to Ground		1000 V peak.
LOW to ground		1000 V peak.
Rear Interface Terminals		
Pin 28B to Pin 28A		200 V peak.
Pin 28B to Ground		200 V peak.
Pin 28A to Ground		200 V peak.

Table 1-2
AC VOLTMETER (TRUE RMS)

Characteristics	Performance Requirements	Supplemental Information
Accuracy for 200 mV, 2 V, 20 V, 200 V, and 500 V ranges:		Automatic or manual ranging.
Front Panel		
+18°C to +28°C		
200 mV to 200 V ranges		
20 Hz to 40 Hz	\pm (1.5% of reading + 0.3% of full scale)	
40 Hz to 20 kHz	\pm (0.6% of reading + 0.3% of full scale)	
500 V range		
20 Hz to 40 Hz	\pm (1.5% of reading + 1.2% of full scale)	
40 Hz to 20 kHz	\pm (0.6% of reading + 1.2% of full scale)	
0°C to +18°C, +28°C to +50°C		
200 mV to 200 V ranges		
20 Hz to 40 Hz	\pm (1.8% of reading + 0.35% of full scale)	
40 Hz to 20 kHz	\pm (0.8% of reading + 0.35% of full scale)	
500 V range		
20 Hz to 40 Hz	\pm (1.8% of reading + 1.4% of full scale)	
40 Hz to 20 kHz	\pm (0.8% of reading + 1.4% of full scale)	
Rear interface	Increase above percent of reading tolerances by 0.5%.	Maximum rear interface input is 200 V peak.

Table 1-2 (cont)

Characteristics	Performance Requirements	Supplemental Information
Usable from 20 kHz to 100 kHz 200 mV to 200 V ranges 500 V range		Typically $\leq \pm(5\%$ of reading + 0.3% of full scale). Typically $\leq +(5\%$ of reading + 1.2% of full scale).
Common Mode Rejection Ratio	≥ 60 dB at 60 Hz	Verified with 1 k Ω unbalance in series with the LOW terminal.
Maximum Resolution		100 μ V.
Response Time		<1 second within any range. Add 1.5 seconds for each range change in the AUTO mode.
Input Impedance		10 M Ω $\pm 0.5\%$ paralleled by <100 pF.
Input Terminals		Front panel (EXT) or rear interface (INT) Switch selectable..
Maximum Input Voltage Front Panel Terminals VOLTS/ Ω to LOW VOLTS/ Ω to Ground LOW to Ground		500 Vrms, not to exceed 1 kV peak. 500 Vrms, not to exceed 1 kV peak. 500 Vrms, not to exceed 1 kV peak.
Rear Interface Terminals Pin 28B to Pin 28A Pin 28B to Ground Pin 28A to Ground		Not to exceed 200 V peak. Not to exceed 200 V peak. Not to exceed 200 V peak.
Crest Factor		4 at full scale on all ranges except 500 V, ≤ 2 on 500 V range.

Table 1-3
DECIBELS (dB)—TRUE RMS

Characteristics	Performance Requirements	Supplemental Information
Accuracy for -10 dB, +10 dB, +30 dB, and +50 dB ranges (Front Panel and Rear Interface)		Automatic or manual ranging. Front panel shows maximum range value with 40 dB below dynamic range.
+18°C to +28°C	± 0.5 dB from +50 dB to -50 dB from 20 Hz to 20 kHz. ± 0.5 dB from -50 dB to -60 dB from 20 Hz to 2 kHz. ± 1.5 dB from -50 dB to -60 dB from 2 kHz to 10 kHz.	Typically $\leq \pm 2.5$ dB from -50 dB to -60 dB from 10 kHz to 20 kHz.

Table 1-3 (cont)

Characteristics	Performance Requirements	Supplemental Information
0°C to +18°C, +28°C to +50°C	<p>±1.1 dB from +50 dB to -50 dB from 20 Hz to 20 kHz.</p> <p>±1.1 dB from -50 dB to -60 dB from 20 Hz to 2 kHz.</p> <p>±2.1 dB from -50 dB to -60 dB from 2 kHz to 10 kHz.</p>	Typically ≤±3.1 dB from -50 dB to -60 dB from 10 kHz to 20 kHz.
Maximum Resolution		0.1 dB.
Response Time		<1 second within any range. Add 1.5 seconds for each range change in the AUTO mode.
Input Impedance		10 MΩ ±0.5% paralleled by <100 pF.
Input Terminals		Front panel (EXT) or rear interface (INT). Switch selectable.
Maximum Input Voltage Front Panel Terminals VOLTS/Ω to LOW VOLTS/Ω to Ground LOW to Ground		500 Vrms, not to exceed 1 kV peak. 500 Vrms, not to exceed 1 kV peak. 500 Vrms, not to exceed 1 kV peak.
Rear Interface Terminals Pin 28B to Pin 28A Pin 28B to Ground Pin 28A to Ground		Not to exceed 200 V peak. Not to exceed 200 V peak. Not to exceed 200 V peak.
Crest Factor		4 at full scale except ≤2 above 40 dB.
Reference Voltage dBV dBm		1 V. 0.7746 V (1 mW dissipated in 600 Ω).
Noise Level		Typically below -75 dB.

**Table 1-4
OHMMETER**

Characteristics	Performance Requirements	Supplemental Information																																										
Accuracy for 200 Ω , 2 k Ω , 20 k Ω , 200 k Ω , 2000 k Ω , and 20 M Ω ranges.		Automatic or manual ranging.																																										
+18°C to +28°C 200 Ω to 2000 k Ω ranges 20 M Ω range	$\pm(0.5\%$ of reading + 0.05% of full scale + 0.2 Ω). $\pm(1\%$ of reading + 0.05% of full scale).																																											
0°C to +18°C, +28°C to +50°C 200 Ω to 2000 k Ω ranges 20 M Ω range	$\pm(0.8\%$ of reading + 0.1% of full scale + 0.2 Ω). $\pm(1.3\%$ of reading + 0.1% of full scale).																																											
Rear Interface	Add 0.5 Ω to the front-panel accuracies stated for the 200 Ω to 2000 k Ω ranges.																																											
Response Time		<1 second within any range. Add 1.5 seconds for each range change in the AUTO mode.																																										
Input Terminals		Front panel (EXT) or rear interface (INT). Switch selectable.																																										
Maximum Input Volts		130 Vdc or ac rms indefinitely. 230 Vdc or ac rms for 1/2 hour (200 V peak at rear interface).																																										
Measuring Current and Full Scale Volts		<table border="1"> <thead> <tr> <th>Range</th> <th>HI-OHMS Current</th> <th>Full Scale Voltage</th> </tr> </thead> <tbody> <tr><td>200 Ω</td><td>1 mA</td><td>0.2 V</td></tr> <tr><td>2 kΩ</td><td>1 mA</td><td>2.0 V</td></tr> <tr><td>20 kΩ</td><td>.1 mA</td><td>2.0 V</td></tr> <tr><td>200 kΩ</td><td>10 μA</td><td>2.0 V</td></tr> <tr><td>2000 kΩ</td><td>1 μA</td><td>2.0 V</td></tr> <tr><td>20 MΩ</td><td>.1 μA</td><td>2.0 V</td></tr> </tbody> </table> <table border="1"> <thead> <tr> <th>Range</th> <th>LO-OHMS Current</th> <th>Full Scale Voltage</th> </tr> </thead> <tbody> <tr><td>200 Ω</td><td>1 mA</td><td>0.2 V</td></tr> <tr><td>2 kΩ</td><td>.1 mA</td><td>0.2 V</td></tr> <tr><td>20 kΩ</td><td>10 μA</td><td>0.2 V</td></tr> <tr><td>200 kΩ</td><td>1 μA</td><td>0.2 V</td></tr> <tr><td>2000 kΩ</td><td>.1 μA</td><td>0.2 V</td></tr> <tr><td>20 MΩ</td><td>.1 μA</td><td>2.0 V</td></tr> </tbody> </table>	Range	HI-OHMS Current	Full Scale Voltage	200 Ω	1 mA	0.2 V	2 k Ω	1 mA	2.0 V	20 k Ω	.1 mA	2.0 V	200 k Ω	10 μ A	2.0 V	2000 k Ω	1 μ A	2.0 V	20 M Ω	.1 μ A	2.0 V	Range	LO-OHMS Current	Full Scale Voltage	200 Ω	1 mA	0.2 V	2 k Ω	.1 mA	0.2 V	20 k Ω	10 μ A	0.2 V	200 k Ω	1 μ A	0.2 V	2000 k Ω	.1 μ A	0.2 V	20 M Ω	.1 μ A	2.0 V
Range	HI-OHMS Current	Full Scale Voltage																																										
200 Ω	1 mA	0.2 V																																										
2 k Ω	1 mA	2.0 V																																										
20 k Ω	.1 mA	2.0 V																																										
200 k Ω	10 μ A	2.0 V																																										
2000 k Ω	1 μ A	2.0 V																																										
20 M Ω	.1 μ A	2.0 V																																										
Range	LO-OHMS Current	Full Scale Voltage																																										
200 Ω	1 mA	0.2 V																																										
2 k Ω	.1 mA	0.2 V																																										
20 k Ω	10 μ A	0.2 V																																										
200 k Ω	1 μ A	0.2 V																																										
2000 k Ω	.1 μ A	0.2 V																																										
20 M Ω	.1 μ A	2.0 V																																										
Maximum Resolution		100 m Ω .																																										
Maximum Open Circuit Voltage		14 V.																																										

**Table 1-5
DC AMMETER**

Characteristics	Performance Requirements	Supplemental Information												
Accuracy for 200 μ A, 2 mA, 20 mA, 200 mA and 2000 mA ranges:		Manual ranging only.												
Front Panel only +18°C to +28°C 0°C to +18°C, +28°C to +50°C	$\pm(0.2\%$ of reading + 0.05% of full scale). $\pm(0.3\%$ of reading + 0.1% of full scale).													
Response Time		<1 second.												
Maximum Open Circuit Input Voltage mA to LOW terminals		250 V peak.												
Maximum Input Current		2 A on any range.												
Input Terminals		Front panel input only.												
Input Resistance		<table border="1"> <thead> <tr> <th>Range</th> <th>Resistance</th> </tr> </thead> <tbody> <tr> <td>200 μA</td> <td>1 kΩ</td> </tr> <tr> <td>2 mA</td> <td>100 Ω</td> </tr> <tr> <td>20 mA</td> <td>10.2 Ω</td> </tr> <tr> <td>200 mA</td> <td>1.2 Ω</td> </tr> <tr> <td>2000 mA</td> <td>0.4 Ω</td> </tr> </tbody> </table>	Range	Resistance	200 μ A	1 k Ω	2 mA	100 Ω	20 mA	10.2 Ω	200 mA	1.2 Ω	2000 mA	0.4 Ω
Range	Resistance													
200 μ A	1 k Ω													
2 mA	100 Ω													
20 mA	10.2 Ω													
200 mA	1.2 Ω													
2000 mA	0.4 Ω													
Maximum Floating Voltage mA terminal to Ground LOW terminal to Ground		1000 V peak. 1000 V peak.												

**Table 1-6
AC AMMETER (TRUE RMS)**

Characteristics	Performance Requirements	Supplemental Information
Accuracy for 200 μ A, 2 mA, 20 mA, 200 mA and 2000 mA ranges:		Manual ranging only.
Front Panel 40 to 10 kHz Sine wave +18°C to +28°C 0°C to +18°C, +28°C to +50°C	$\pm(0.6\%$ of reading + 0.3% of full scale). $\pm(0.7\%$ of reading + 0.5% of full scale).	Useable to 20 kHz.
Response Time		<1 second.
Maximum Open Circuit Input Voltage mA to LOW terminals		250 V peak.
Maximum Input Current		2 A on any range.
Input Terminals		Front panel input only.
Input Resistance		Same as for dc ammeter.
Maximum Floating Voltage mA terminal to Ground LOW terminal to Ground		1000 V peak. 1000 V peak.

**Table 1-7
TEMPERATURE**

Characteristics	Performance Requirements	Supplemental Information
Accuracy for the -55°C to $+200^{\circ}\text{C}$ range:		Manual ranging only.
$+18^{\circ}\text{C}$ to $+28^{\circ}\text{C}$ Ambient P6601 Probe calibrated to instrument	$\pm 2.5^{\circ}\text{C}$ from -55°C to $+150^{\circ}\text{C}$. $\pm 3.5^{\circ}\text{C}$ from $+150^{\circ}\text{C}$ to $+200^{\circ}\text{C}$.	
Any P6601 probe	$\pm 4.5^{\circ}\text{C}$ from -55°C to $+150^{\circ}\text{C}$. $\pm 5.5^{\circ}\text{C}$ from $+150^{\circ}\text{C}$ to $+200^{\circ}\text{C}$.	
0°C to $+18^{\circ}\text{C}$, $+28^{\circ}\text{C}$ to $+50^{\circ}\text{C}$ Ambient Probe calibrated to instrument	$\pm 4^{\circ}\text{C}$ from -55°C to $+150^{\circ}\text{C}$. $\pm 5^{\circ}\text{C}$ from $+150^{\circ}\text{C}$ to $+200^{\circ}\text{C}$	
Any probe	$\pm 6^{\circ}\text{C}$ from -55°C to $+150^{\circ}\text{C}$. $\pm 7^{\circ}\text{C}$ from $+150^{\circ}\text{C}$ to $+200^{\circ}\text{C}$.	
Input Terminals		Front panel only.

**Table 1-8
MISCELLANEOUS**

Characteristics	Description
Power Consumption	Approximately 8 W.
Reading Rate	3 per second.
Over-Range Indication	Flashing display except 1000 Vdc and 500 Vac ranges.
Warm-up Time	30 minutes (60 minutes after storage in high humidity environment).

ENVIRONMENTAL CHARACTERISTICS

Table 1-9

ENVIRONMENTAL^a

Characteristics	Description	
Temperature Operating Nonoperating	0° C to +50° C ^b -55° C to +75° C	Test to MIL-T-28800B, class 5 with exceptions ^d .
Humidity Operating Nonoperating	+30° C and +50° C to 90%, +5 -0% ^b +30° C to +60° C to 90%, +5 -0%	Test to MIL-T-28800B, class 5.
Altitude Operating Nonoperating	4.5 km (15,000 ft.) ^b 15 km (50,000 ft.)	Test to MIL-T-28800B, class 3.
Vibration Operating	0.64 mm (0.025") disp., 5-55-5 Hz ^{a/c} (sine wave) 75 min. total	Test to MIL-T-28800B, class 3.
Shock Nonoperating	50 g's (1/2 sine) 11 ms ^{a/c} 18 shocks	Test to MIL-T-28800B, class 3.
Bench Handling Operating	45° or 4" or equilibrium ^c , whichever occurs first.	Test to MIL-T-28800B, class 3.
E.M.C. Operating	30 Hz to 1 GHz ^b	Test to MIL-T-28800B, class 3.
Electrical Discharge Operating	20 kV max. ^b	Charge applied to each protruding area of the product under test except the input terminals. No MIL-T-28800 equivalent..
Transportation		Qualified under National Transit Association Pre-shipment Test Procedures Project: 1A-B-1 and 1A-B-2.

^a See Table 1-10 for system modifiers.

^b With power module.

^c Without power module.

^d Temperature: During low temperature test MIL-T-28800B, paragraph 4.5.5.1.3(b) for class 5, steps 4 and 5 shall be performed before step 2. Also, the instrument shall not be operating during step 6, paragraph 4.5.5.1.3(e), class 5. While operating, condensed moisture shall not be present on class 5 instruments. Drying of the instrument for this class may be performed in a suitable chamber, if necessary.

Table 1-10
TM 500 SYSTEMS
ENVIRONMENTAL SPECIFICATIONS

Characteristics	TM 501	TM 503	TM 504	TM 506	TM 515
Temperature Operating Nonoperating	Meets same test standards as plug-in.				
Humidity Operating Nonoperating	Meets same test standards as plug-in.				
Altitude Operating Nonoperating	Meets same test standards as plug-in.				
Vibration Operating	0.26 mm (0.010 in) disp., 10-55 Hz (sine wave) 75 min. total			0.38 mm (0.015 in) disp. 10-55 Hz (sine wave) 75 min.	
Shock Operating	20 g's (1/2 sine) 11 ms, 18 shocks			30 g's (1/2 sine) 11 ms, 18 shocks	
Bench Handling Operating	Meets same test standards as plug-in.				
Electric Discharge Operating	Meets same test standards as plug-in.				
Transportation Vibration Package Drop	Meets same test standards as plug-in.				

Table 1-11
PHYSICAL CHARACTERISTICS

Characteristics	Description
Finish	Anodized aluminum panel and chassis
Net Weight	≈2.5 lbs. (1.13 kg).
Overall Dimensions	2.633 in (66.8 mm) W x 11.240 in (285.3 mm) D x 4.961 in (125.9 mm) H.

OPERATING INSTRUCTIONS

Installation and Removal

The DM 502A is calibrated and ready for use when received. It operates in any compartment of a TM 500 series power module. See the power module instruction manual for line voltage requirements and power module operation. Figure 2-1 shows the DM 502A installation and removal procedure.

CAUTION

Turn the power module off before inserting the DM 502A. Otherwise, arcing may occur at the rear interface connectors, reducing their useful life and damage may be done to the plug-in circuitry.

Before installing the DM 502A in the power module, make certain that the internal jumper is set for the desired dB mode of operation, dBm, or dBV. Refer the setting of this jumper to qualified personnel.

Check to see that the plastic barriers on the interconnecting jack of the selected power module compartment match the cutouts in the DM 502A circuit board edge connector. Align the DM 502A chassis with the upper and lower guides of the selected compartment. Press the DM 502A in and firmly seat the circuit board in the interconnecting jack.

To remove the DM 502A pull the release latch (located in the lower left corner) until the interconnecting jack disengages and the DM 502A slides out.

Check that the DM 502A is fully inserted in the power module. Pull the power switch on the power module. One or more characters in the LED display should now be visible.

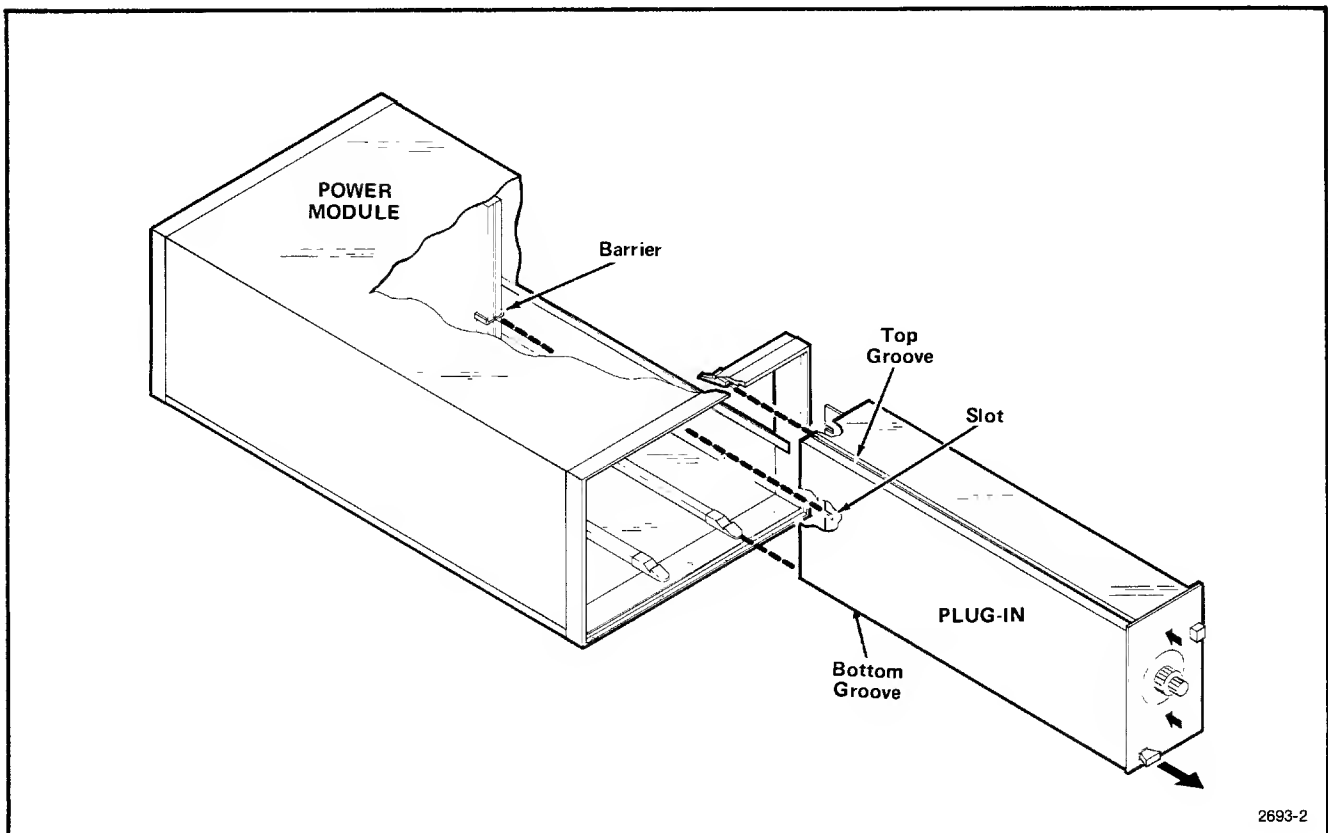



Fig. 2-1. Installation and removal.

Controls, Connectors, and Indicators

All controls, connectors, and indicators (except for the rear interface connector and the internal jumper used to select readout for the dBm or dBV modes) required for operation of the DM 502A are located on the front panel. Figure 2-2 provides a brief description of all front-panel controls, connectors, and indicators.

- 1 Display**
 3 1/2 digit LED readout with properly positioned decimal point. Special scale factors are illuminated by separate LEDs.
- 2 μ A**
 Illuminated when units are microamperes.
- 3 mV**
 Illuminated when units are millivolts.
- 4 Ω**
 Illuminated when units are Ohms.
- 5 M Ω**
 Illuminated when units are megohms.
- VOLTS**

 - 6 DC**
 Selects dc voltage ranges.
 - 7 VOLTS AC TRUE RMS**
 Selects ac voltage ranges.

dBm/dBV 
 See Decibel Measurements on page 2-4.
- 8 dB**
 Selects dB ranges when depressed along with AC VOLTS TRUE RMS. Reference dBm or dBV is internally selectable.
- 9 k Ω**
 Selects resistance measuring ranges.
- 10 HI-LO**
 Button in selects full scale voltage as 0.2 in all ranges except 20 M Ω which is 2 V. Button out selects full scale voltage as 2 except in 200 Ω range which is 0.2 V.



- mA**

 - 11 DC**
 Selects dc current measuring range.
 - 12 AC**
 Selects ac current measuring ranges.

- 13 INPUT EXT-INT** 
 Button out selects front panel input; button in selects rear interface input for dc and ac volts, resistance and current measurements only.



The maximum input voltage is 1 kV peak at the front panel connectors and 200 V peak at the rear interface connectors. The front panel VOLTS/ Ω and LOW connectors may be floated 1 kV maximum above ground, the rear input connectors 200 V.

- 14 TEMP °C**
 Select temperature readout in °C.
- 15 mA** 
 Use in conjunction with LOW terminal for current measurements.
- 16 LOW** 
 Common terminal for all inputs except temperature.
- 17 TEMP**
 Connect temperature probe to this terminal.
- 18 Ground Terminal**
 Chassis ground.
- 19 VOLTS/ Ω** 
 Use in conjunction with LOW terminal for voltage and resistance measurements.
- 20 AUTO (20 M Ω)**
 Selects automatic ranging for dc and ac voltage, dB and resistance. The 20 M Ω range is available only in the automatic mode.
- 21 Range Select Pushbuttons**
 Press these buttons to select the desired measurement ranges.

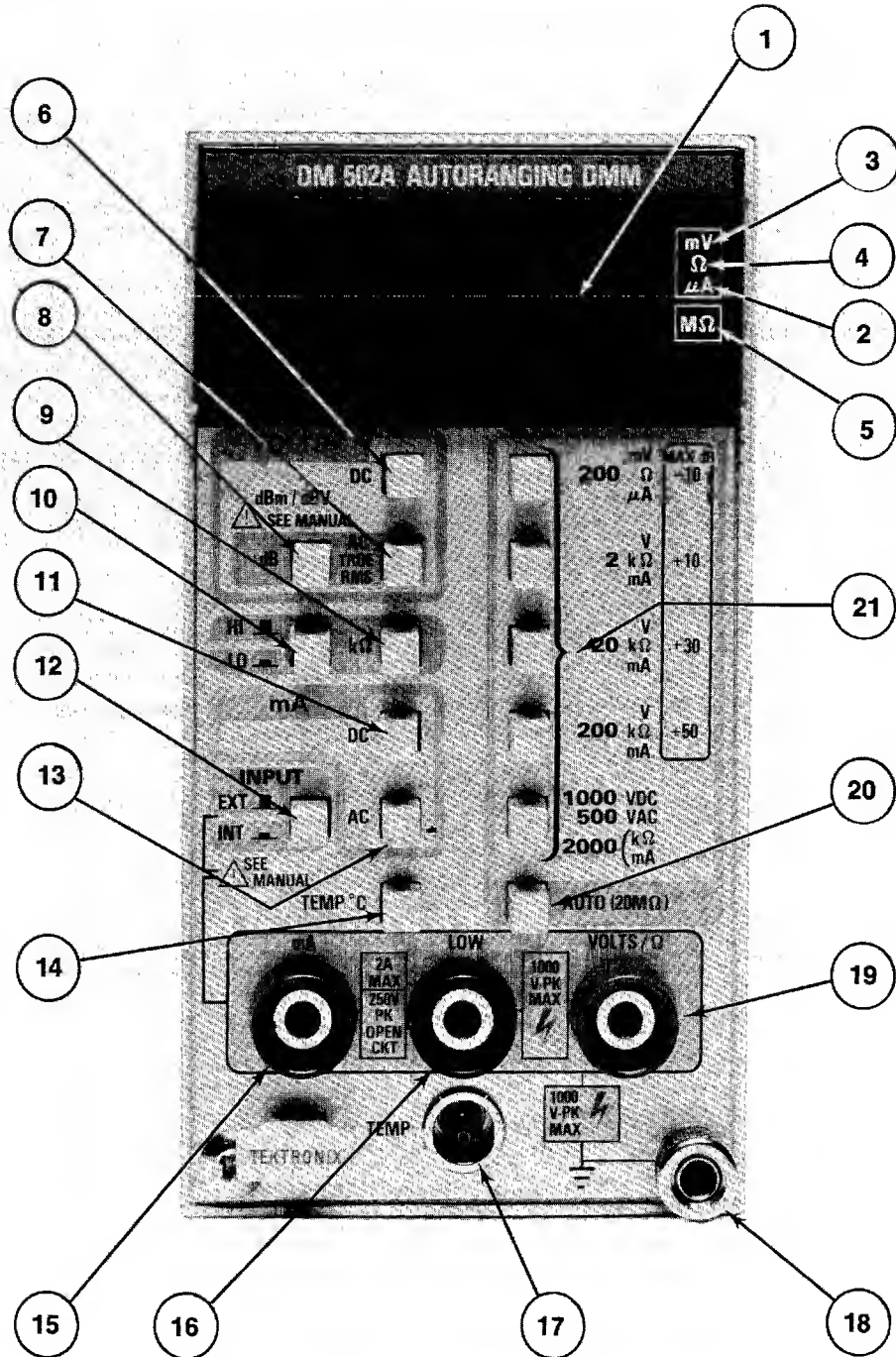

Fig. 2-2. Front panel controls and connectors.

Input Connections



If the INPUT button is pressed, signal inputs are made via the rear interface connector (INT); if the button is out, signal inputs are made via the front panel connector (EXT).



The maximum input voltage is 1 kV peak at the front panel connectors and 200 V peak at the rear interface connectors. The front panel VOLTS/Ω and LOW connectors may be floated 1 kV maximum above ground, the rear input connectors 200 V.

Three input jacks provide measurement connections. The VOLTS/Ω and LOW input jacks are normally used for all measurements except current and temperature. Normal measurement conditions will be with the LOW terminal ungrounded. A connection between the LOW and GND input jack post may be made to reference the input against DM 502A chassis ground. Use caution, as the LOW terminal is then connected to earth ground through the three-wire power cord. False readings may be obtained due to ground loops.

Making Measurements

With the DM 502A properly installed in the power module, allow 30 minutes warmup time for operation to specified accuracy. Select the desired measurement mode: voltage, decibels, resistance, current, or temperature. Then select the desired measurement range or the automatic (AUTO) range in all modes except current and temperature. When the value of the measurand is unknown, use the automatic mode. Units of measurement are volts, decibels, kilohms, milliamperes or degrees centigrade unless the appropriate suffix μA (microamperes), mV (millivolts), Ω (Ohms) or MΩ (megohms) is illuminated at the right of the display. The decimal point is automatically positioned. To use the 20 MΩ range push the button marked AUTO (20 MΩ). If the autoranging feature is not desired, push the desired measurement range button. The measurement units are read the same as in the automatic mode of operation.

Dc Voltage Measurements

Press the VOLTS DC pushbutton and AUTO or the desired measurement range button. Apply the voltage to be measured to the VOLTS/Ω and LOW connectors. Observe the maximum voltage ratings. The readout displays a + if the VOLTS/Ω input is positive with respect to the LOW input. A - is displayed if the LOW input is more positive. With the input shorted, the display reads zero, ± one count.

Ac Voltage Measurements

Press the VOLTS AC TRUE RMS and AUTO or the desired measurement range button. Apply the voltage to be measured to the VOLTS/Ω and LOW connectors. Observe the maximum input voltage ratings.

Decibel Measurements



Press the VOLTS AC TRUE RMS, dB, and AUTO or the desired measurement range pushbutton. The DM 502A will read directly in dBm or dBV depending on the position of the internal jumper. This jumper is located on the main board in the upper rear quadrant and is numbered P1517.

WARNING

Refer jumper change to qualified personnel.

The formula for calculating dB from voltage is:

$$\text{dB} = 20 \log_{10} \frac{E_2}{E_1}$$

When the DM 502A is set for dBV, 1 V is the reference voltage (E_1) in the formula and the instrument calculates and displays the dBV value. When the jumper is set for dBm, the reference voltage is 0.7746 V, the equivalent of 1 mW dissipated in 600 Ω. The unknown voltage is E_2 .

Resistance Measurements

Connect the resistance to be measured to the VOLTS/Ω and LOW input terminals. Select the maximum resistance measuring range desired by pressing the appropriate pushbutton or the AUTO pushbutton if automatic ranging is desired. Press the kΩ and the HI or LO pushbutton depending on the voltage desired at the measurement terminals. The voltage at the measurement terminals with the LO pushbutton pressed is 0.2 V in all ranges except 20 MΩ, which is 2.0 V. With the HI pushbutton pressed the voltage is 2.0 V in all ranges except 200 Ω which is 0.2 V. Use the LO ranges (lower voltage) for incircuit resistance measurements where diode junctions might be forward biased with the higher voltages.

Current Measurements

Connect the ac or dc current to be measured to the mA and LOW input connections. Observe the maximum voltage ratings. Press the mA, DC, or AC pushbuttons and the current range desired. The DM 502A does not auto range in the current modes.

Temperature Measurements

Connect the P6601 temperature probe to the front panel TEMP connector. Use care to align the connector pins. Press the TEMP °C button. For best accuracy calibrate the individual instrument to the probe used. Apply the probe sensor tip to the device being measured. For optimum temperature transfer, coat the surface of the device being measured with silicone grease and apply the probe tip squarely to the surface. Allow sufficient time for the probe tip to stabilize before taking a reading. The time required depends on several factors. Generally, when the tip is first applied to the device under test, the readings change less rapidly and finally stabilize.

See the P6601 manual for more information on temperature measurements and probe use.

Repackaging Information

If the Tektronix instrument is to be shipped to a Tektronix Service Center for service or repair, attach a tag showing the owner (with address) and the name of an individual at your firm that can be contacted. Include the complete instrument serial number and a description of the service required.

Save and re-use the package in which your instrument was shipped. If the original packaging is unfit for use or not available, repackage the instrument as follows:

Surround the instrument with polyethylene sheeting to protect the finish of the instrument. Obtain a carton of corrugated cardboard of the correct carton strength and having inside dimensions of no less than six inches more than the instrument dimensions. Cushion the instrument by tightly packing three inches of dunnage or urethane foam between carton and instrument on all sides. Seal the carton with shipping tape or an industrial stapler.

The carton test strength for this instrument is 200 pounds per square inch.

INSTRUCTIONS D'UTILISATION

Description de l'appareil

Le multimètre numérique DM 502A effectue des mesures de tension continue et alternative, des mesures en décibels (dBm et dBV) ainsi que des mesures de résistance et de température. En alternatif, le DM 502A calcule la valeur efficace vraie. Les gammes de mesure de tension continue, alternative, les mesures en niveaux (dBm, DBV) ainsi que les mesures de résistance, sont sélectionnées automatiquement ou manuellement. Les gammes de mesure de courant et de température sont sélectionnées manuellement.

L'entrée par l'interface arrière est sélectionnée par un bouton poussoir à partir du panneau avant. L'affichage s'effectue en dBm ou en dBV, selon la position d'un cavalier interne (l'appareil est livré avec ce cavalier placé en position dBm).

Accessoires

Les accessoires standard comprennent le manuel d'utilisation, un jeu de fils de liaison ainsi que la sonde de température

re Tektronix P6601. L'option 02 élimine les mesures de température, la sonde n'est pas fournie dans ce cas.

Conditions de vérification des performances

Les caractéristiques électriques ne sont valables que si le DM 502A a été étalonné à une température ambiante comprise entre $+21^{\circ}\text{C}$ et $+25^{\circ}\text{C}$. L'appareil doit fonctionner dans une plage de température comprise entre 0°C et $+50^{\circ}\text{C}$.

Instructions d'installation

Le multimètre numérique DM 502A est livré étalonné et prêt à fonctionner. Il peut être utilisé dans n'importe quel châssis d'alimentation de la série TM 500 (veuillez vous reporter au manuel d'instructions du châssis d'alimentation pour toute information relative à la tension du réseau et à son utilisation). La figure 2-1 montre la façon de mettre ou de retirer la DM 502A.

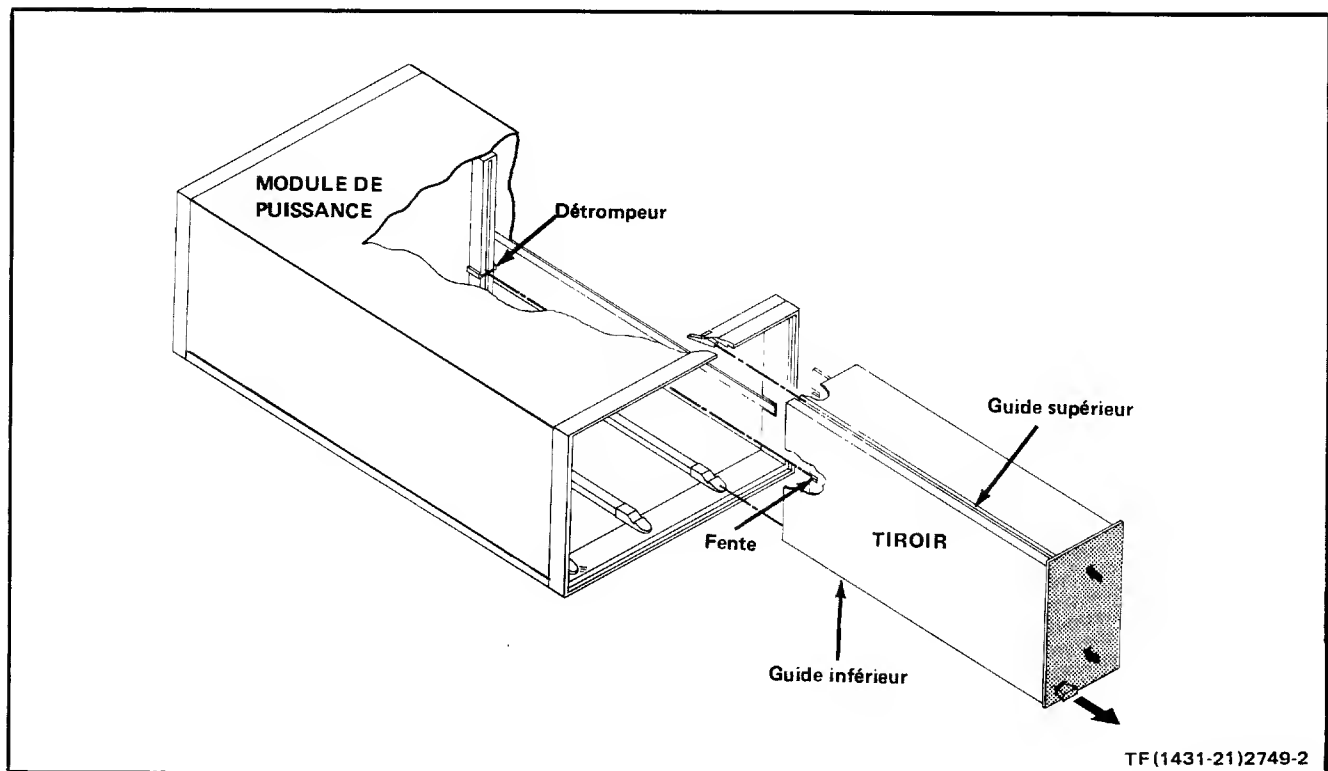

Fig. 2-1. Installation et démontage du DM 502A.

ATTENTION

Couper l'alimentation du châssis avant d'insérer ou d'extraire le DM 502A. Des arcs pourraient se produire sur les connecteurs au niveau de l'interface arrière (réduisant ainsi leur durée de vie) et risqueraient d'endommager les circuits du tiroir.

Avant d'installer le DM 502A dans le châssis d'alimentation, assurez-vous que le cavalier interne est mis pour fonctionner dans le mode désiré : dBm ou dBV. Seul, un personnel qualifié peut intervenir sur ce matériel.

Vérifier que les détrompeurs situés sur le connecteur du châssis d'alimentation choisi s'adaptent aux encoches situées sur le connecteur du circuit imprimé du DM 502A. Aligner ensuite les rainures supérieure et inférieure du DM 502A avec les guides du châssis d'alimentation. Insérer à fond le DM 502A.

Pour extraire le DM 502A, tirer le loquet de verrouillage (situé au coin inférieur gauche) jusqu'à ce que le connecteur arrière soit libéré. Faire ensuite glisser l'appareil vers l'extérieur.

Vérifier que le DM 502A est parfaitement enfiché dans le châssis d'alimentation. Un ou plusieurs caractères de l'affichage DEL doit apparaître dès la mise sous tension.

Commandes, bornes d'entrées et voyants lumineux

Toutes les commandes, bornes et voyants lumineux nécessaires à l'utilisation du DM 502A sont situés sur le panneau avant (sauf pour la signalisation et la mise en place du cavalier dBm-dBV ainsi que l'accès au connecteur arrière). La figure 2-2 montre brièvement les commandes, bornes d'entrées et voyants du DM 502A.

- 1 **Affichage**
L'affichage à 3 1/2 chiffres est réalisé par diodes électroluminescentes, avec positionnement automatique de la virgule. Les facteurs d'échelle spécifiques sont indiqués par des DEL séparées. L'indication de la polarité est automatique.
- 2 μA
S'allume lorsque les unités choisies pour effectuer des mesures de courant sont des microampères.
- 3 mV
S'allume lorsque les unités choisies pour effectuer des mesures de tension sont des mV.
- 4 Ω
S'allume lorsque les unités choisies pour effectuer des mesures de résistance sont des Ohms.

- 5 M Ω
S'allume lorsque les unités choisies pour effectuer des mesures de résistance sont des Megohms.

Tensions

- 6 DC
Sélectionne les gammes de tension continue.
- 7 **VOLTS AC TRUE RMS**
Tension alternative vraie efficace. Sélectionne les gammes de tension alternative.

dBm/dBV



Se reporter au paragraphe traitant des mesures de niveaux (dB), page 2-4.

- 8 dB
Engagée conjointement avec le bouton AC VOLTS TRUE RMS, cette commande sélectionne les gammes de niveaux en dB. Un cavalier interne sélectionne la référence dBm ou dBV.
- 9 k Ω
Sélectionne les gammes de mesures de résistance.
- 10 **HI-LO**
En position enfoncé, cette commande fixe la tension maximale à pleine échelle sur toutes les gammes à 0.2 V max. sauf pour la gamme 20 M Ω , dont la tension est de 2 V max. En position sorti, elle sélectionne la tension à pleine échelle à 2 V max. sauf pour la gamme 200 Ω dont la tension max. est de 0.2 V.

mA

- 11 DC
Sélectionne les gammes de mesures de courant continu.
- 12 **INPUT EXT/INT**
En position sorti, cette commande sélectionne l'entrée située sur le panneau avant. En position enfoncé, elle sélectionne les entrées au niveau de l'interface arrière (dans ce cas uniquement pour les mesures de tension alternative et continue, les mesures de résistance et les mesures de courant).
- 13 AC
Sélectionne les gammes de mesures de courant alternatif.

ATTENTION

La tension d'entrée maximale autorisée est de 1 kV sur les bornes du panneau avant et de 200 V sur le connecteur de l'interface arrière. La tension d'entrée maximale appliquée sur les entrées VOLTS/ Ω et LOW, par rapport au châssis, est de 1 kV sur les bornes du panneau avant et de 200 V sur l'interface arrière.

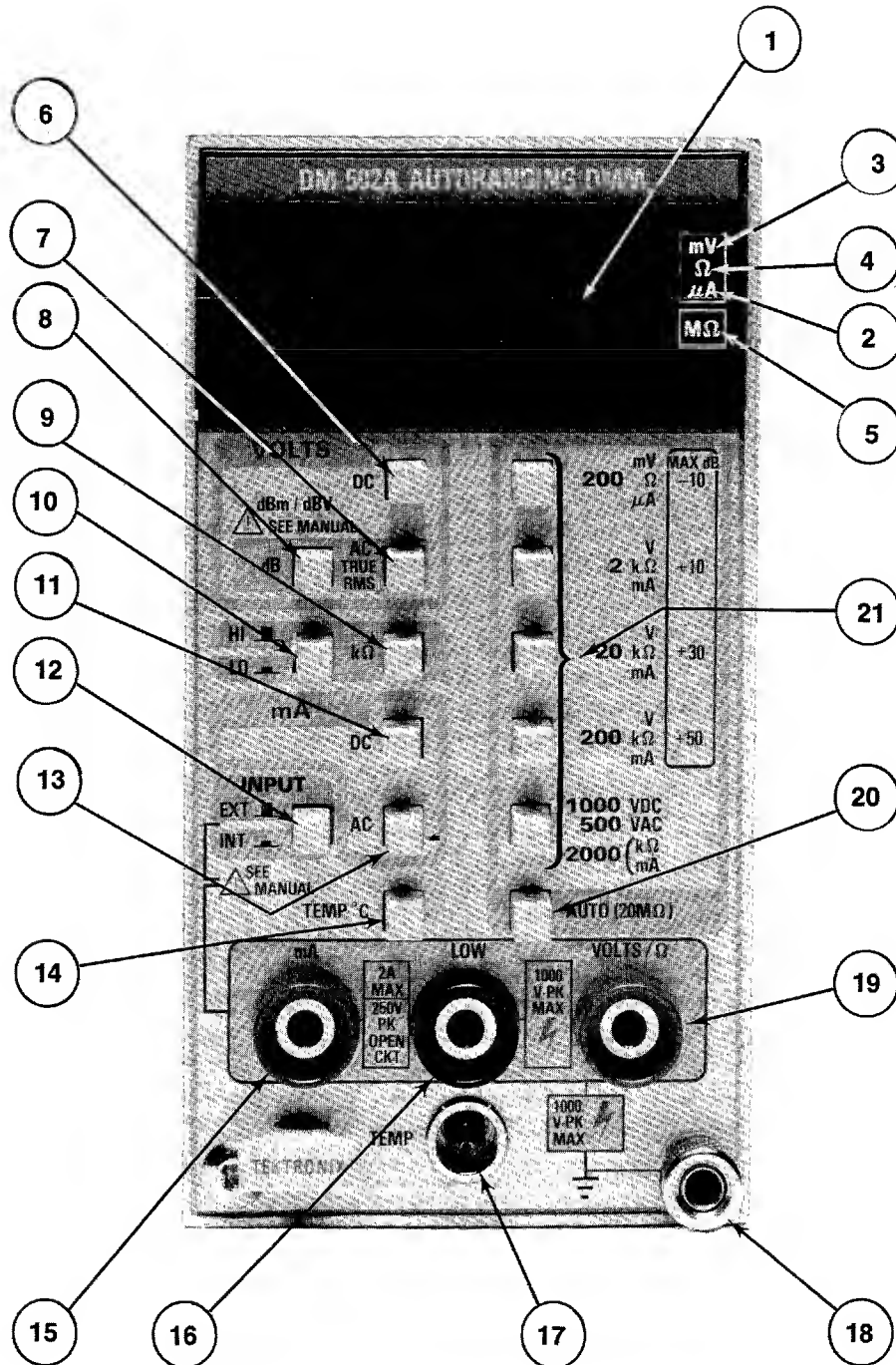

Fig. 2-2. Commandes et connecteurs.

14 TEMP °C
Sélectionne l'affichage des mesures de température en °C.

15 mA
Utilisée conjointement avec la borne LOW pour les mesures de courant.

16 LOW
Borne commune pour toutes les entrées, sauf pour les mesures de température.

17 TEMP
Connecte la sonde de température à cette entrée.

Borne de mise à la masse
Masse du châssis.

18 VOLTS/Ω
Utilisée conjointement avec la borne d'entrée LOW pour effectuer les mesures de tension et de résistance.

19 AUTO (20 MΩ)
Cette commande autorise la sélection automatique de la gamme pour les mesures de tension continue et alternative, en niveaux (dB) et de résistance. La gamme 20 MΩ n'est disponible qu'en mode automatique.

Boutons poussoirs de sélection de gamme
Appuyer sur ces boutons pour sélectionner la gamme de mesure désirée.

Connexions d'entrée

Si le bouton d'entrée INPUT est engagé, les entrées du signal s'effectuent par l'interface arrière (INT). En position sorti, les entrées s'effectuent par l'intermédiaire des bornes du panneau avant (EXT).

ATTENTION

La tension d'entrée maximale autorisée est de 1 kV sur les bornes du panneau avant et de 200 V sur le connecteur de l'interface arrière. La tension d'entrée maximale appliquée sur les entrées VOLTS/Ω et LOW, par rapport au châssis, est de 1 kV sur les bornes du panneau avant et de 200 V sur l'interface arrière.

Trois bornes d'entrée permettent l'entrée des signaux. Les bornes d'entrée VOLTS/Ω et LOW sont généralement utilisées pour toutes les mesures, exception faite des mesures de courant et de température. Normalement, la borne d'entrée LOW n'est pas reliée à la masse. Une liaison peut être établie entre la borne d'entrée LOW et la borne de masse afin de référencer l'entrée au châssis de l'appareil. La borne LOW est alors connectée à la terre par l'intermédiaire du câble d'alimentation. Les erreurs de mesures dues à d'éventuelles boucles de courant de masse peuvent alors se produire.

Réalisation des mesures

Le DM 502A étant correctement mis en place et le châssis d'alimentation placé sous tension, il est nécessaire de prévoir un temps de chauffe de 30 minutes afin que l'appareil fonctionne avec la précision annoncée. Sélectionner ensuite la nature de la mesure désirée : tension, niveau (dB), résistance, courant ou température. Puis sélectionner ensuite la gamme de mesure désirée ou le mode automatique (AUTO) (excepté pour les mesures de courant et de température). Lorsque la valeur de la quantité mesurée est inconnue, utiliser le mode automatique. Les unités de mesures sont : volts, décibels, kilohms, milliampères ou degrés centigrades, à moins que le suffixe approprié μA, mV, Ω ou MΩ ne s'allume à droite de l'affichage. La virgule se positionne automatiquement. Pour utiliser la gamme 20 MΩ, appuyer sur le bouton marqué AUTO (20 MΩ). Si l'on ne souhaite pas utiliser le mode automatique, appuyer sur le bouton de sélection de la gamme désirée. En mode automatique, les unités de mesures se lisent de la même manière que dans le mode manuel.

Mesures de tension continue

Appuyer sur le bouton poussoir VOLTS/DC et AUTO (ou sur le bouton de sélection de la gamme désirée). Appliquer la tension à mesurer sur les bornes d'entrée VOLTS/Ω et LOW. S'assurer que la tension d'entrée maximale n'est pas dépassée. L'affichage indiquera un + si l'entrée de la prise VOLTS/Ω est positive par rapport à l'entrée LOW et un - dans le cas contraire. Si les entrées VOLTS/Ω et LOW sont réunies entre elles (court-circuit), l'affichage doit indiquer 0 ± 1 point.

Mesures de tension alternative

Appuyer sur les boutons VOLTS AC TRUE RMS et AUTO ou sur le bouton de sélection de la gamme désirée. Appliquer la tension à mesurer sur les bornes VOLTS/Ω et LOW. S'assurer que la tension d'entrée maximale n'est pas dépassée.

Mesures de niveaux (décibels)

Appuyer sur les boutons VOLTS AC TRUE RMS, dB et AUTO ou sur le bouton de sélection de la gamme de mesure désirée. Le DM 502A affichera directement le résultat de la mesure en dBm ou en dBV, en fonction de la position du cavalier interne. (Ce cavalier se situe sur le circuit imprimé principal dans le quadrant supérieur arrière et est référencé P1517).

AVERTISSEMENT

Toute intervention à l'intérieur du DM 502A doit être effectuée par un personnel qualifié.

La formule à appliquer pour calculer la valeur en dB, à partir d'une tension est la suivante :

$$\text{dB} = 20 \log_{10} \frac{E_2}{E_1}$$

Lorsque le DM 502A est utilisé pour des mesures en dBV, la valeur de référence est d'un volt dans la formule (E_1). L'appareil calcule et affiche le résultat en dBV. Lorsque le cavalier est positionné pour des mesures en dBm, la tension de référence est 0,776 V (l'équivalent de 1 mW dissipé dans 600 Ω). La tension inconnue est E_2 .

Mesures de résistance

Appliquer la résistance à mesurer sur les bornes d'entrée VOLTS/ Ω et LOW. Sélectionner la gamme de mesure désirée en appuyant sur le bouton poussoir approprié ou sur le bouton AUTO si le mode automatique est choisi. Appuyer sur le bouton poussoir k Ω et le bouton HI-LO suivant la tension désirée pour la mesure. La tension disponible sur les bornes de mesures, la commande LOW étant engagée, est de 0,2 V max. sur toutes les gammes, excepté celle de 20 M Ω qui est de 2,0 V. Lorsque la commande HI est engagée, la tension est de 2.0 V max sur toutes les gammes, excepté celle de 200 Ω dont la tension max est de 0,2 V. Utiliser la gamme LO (faible tension) pour les mesures de résistance dans les circuits de façon à éviter la polarisation directe des semi-conducteurs au silicium.

Mesures de courant

Appliquer le courant alternatif ou continu à mesurer aux bornes d'entrée mA et LOW. S'assurer que la tension d'entrée maximale n'est pas dépassée. Appuyer sur les boutons mA, DC ou AC et sur le bouton de la gamme de courant désirée. (Le mode automatique ne fonctionne pas en mesures de courant).

Mesures de température

Relier la sonde de température P6601 à la prise TEMP placée sur le panneau avant. (Procéder avec soin à l'alignement des broches du connecteur). Appuyer sur le bouton poussoir TEMP °C (pour une meilleure précision, étalonner l'appareil avec la sonde utilisée). Appliquer l'extrémité sensible de la sonde à l'élément sous test (pour un transfert op-

timal de température, la surface de l'élément dont la température est à mesurer doit être recouverte de graisse de silicone). Attendre suffisamment pour que la température de l'embout de la sonde soit stabilisée avant d'effectuer une mesure. Le temps nécessaire à cette stabilisation est fonction de plusieurs facteurs.

Se reporter au manuel P6601 pour toute information complémentaire sur les mesures de température et sur l'utilisation de la sonde.

Instructions de réemballage pour expédition

Si un appareil Tektronix doit être expédié à un centre de maintenance Tektronix, pour entretien ou réparation, attachez à l'appareil une étiquette portant les indications suivantes : nom du propriétaire, l'adresse complète et le nom du responsable pouvant être contacté. Ne pas oublier de mentionner le type complet de l'instrument, le numéro de série et une description de l'intervention souhaitée.

Nous vous recommandons de conserver le carton et le matériel d'emballage d'origine dans lequel vous avez reçu votre appareil. Si vous n'avez pas préservé ceux-ci, emballez l'instrument de la manière suivante :

- . Procurez-vous une boîte de carton ondulé dépassant d'au moins 15 cm les dimensions de l'appareil de manière à pouvoir entourer celui-ci de matériaux protecteurs.
- . Entourez l'instrument d'une feuille de polyéthylène de manière à assurer la protection du boîtier.
- . Intercalez entre le carton et l'instrument de la mousse d'uréthane, d'une épaisseur de 7,6 cm de chaque côté.
- . Fermez le carton au moyen d'une bande adhésive ou d'une grosse agrafeuse industrielle.

Test de résistance de l'emballage pour cet appareil : 15 kg/cm².

BEDIENUNGSANLEITUNG DM 502A

Ein- und Ausbauanweisung

Das Digitalmultimeter DM 502A wird kalibriert und gebrauchsfertig geliefert. Es muß zur Anwendung in ein Einschubfach einer TM 500 Versorgungseinheit eingesetzt werden. Für die Bedienung und die korrekte Einstellung der erforderlichen Netzspannung beziehen Sie sich bitte auf die Bedienungsanleitung der Versorgungseinheit. Bild 2-1 zeigt den Ein- und Ausbavorgang des DM 502A.

VORSICHT

Vor dem Einsetzen oder Herausnehmen des DM 502A ist die Versorgungseinheit unbedingt auszuschalten. Dadurch wird an den rückseitigen Kontaktleisten Funkenbildung vermieden, die die Funktionsdauer der Kontakte einschränken würde und evtl. Schaltkreise im Gerät beschädigen könnte.

Bevor Sie das DM 502A in die Versorgungseinheit einsetzen, vergewissern Sie sich, ob die interne Verbindungsbrücke auf die richtige dB-Betriebsart dBm oder dBV eingestellt ist. Die Einstellung ist nur von geschultem Personal vorzunehmen.

Überprüfen Sie, ob der Plastiksteg der Verbindungsbuchse im Fach der Versorgungseinheit mit dem Ausschnitt in der Steckverbindungsleiste der DM 502A Platine übereinstimmt. Setzen Sie das DM 502A-Chassis in die obere und untere Führung des gewählten Faches und schieben es mit dem nötigen Druck soweit ein, bis die rückseitige Steckverbindungsleiste einrastet.

Zum Herausnehmen des DM 502A ziehen Sie die Entriegelungsklinke an der linken unteren Ecke des Einschubes, bis sich die rückseitige Steckverbindung löst. Nun kann das DM 502A dem Fach entnommen werden.

Überprüfen Sie, ob das DM 502A korrekt in die Versorgungseinheit eingesetzt ist und schalten Sie den Netzschalter ein. Es sollte nun die LED-Anzeige leuchten.



Abb. 2-1: Ein- und Ausbau des Digitalmultimeters DM 502A

Bedienungselemente, Steckverbindungen und Anzeigen.

Alle Bedienungselemente, Steckverbindungen und Anzeigen (ausgenommen für die rückseitige Interface-Leiste und die interne Brücke zur Wahl der dB-Betriebsart dBm oder dBV) die zum Betrieb des DM 502A erforderlich sind, befinden sich auf der Frontplatte.

Bild 2-2 dient zur Erklärung der Bedienungselemente, Steckverbindungen und Anzeigen.

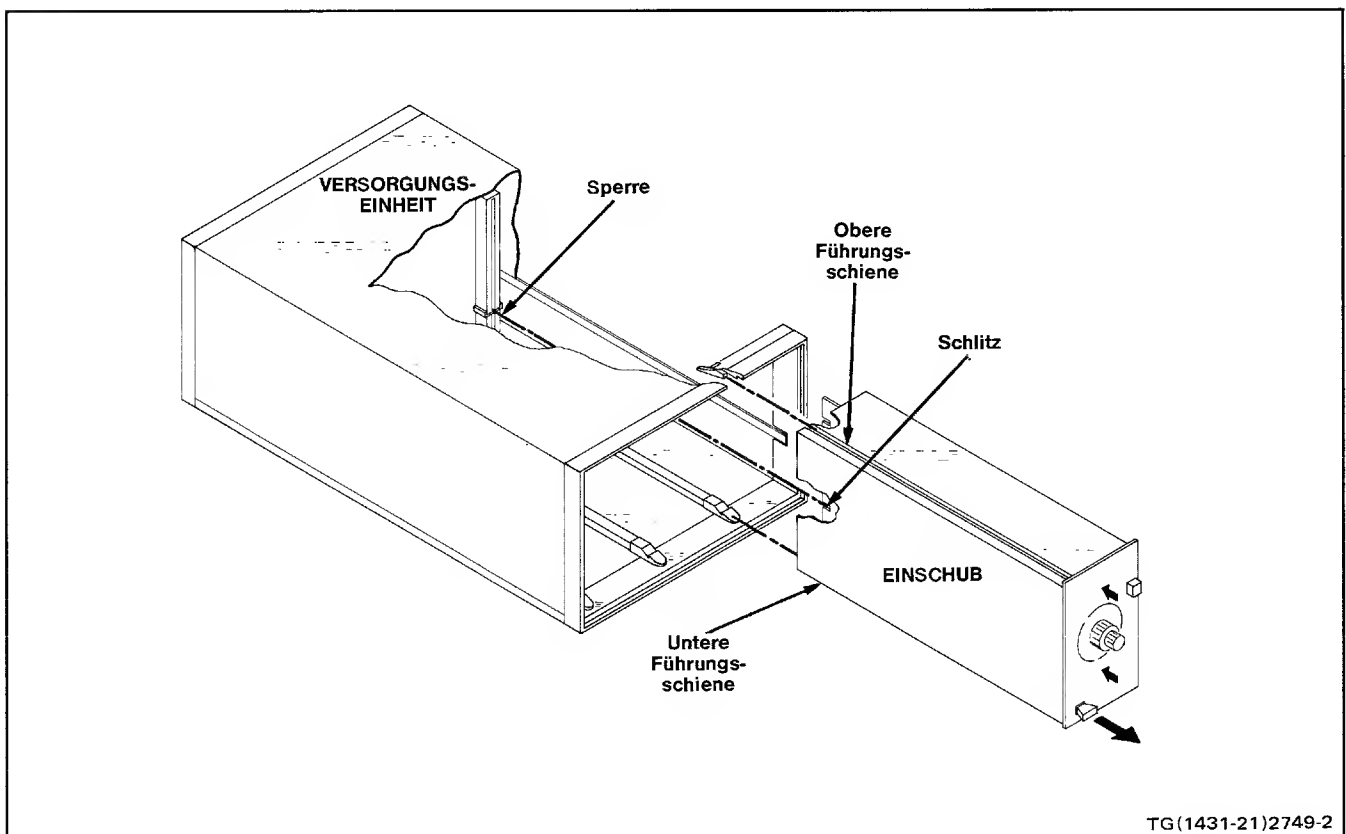
① **Display**
3 1/2stellige LED-Anzeige mit automatischer Dezimalpunktpositionierung. Die Skalenfaktoren werden durch separate LED's gekennzeichnet.

② **µA**
Leuchtet, wenn der µA-Bereich eingeschaltet ist.

③ **mV**
Leuchtet, wenn der mV-Bereich eingeschaltet ist.

④ **Ω**
Leuchtet, wenn der Ω-Bereich eingeschaltet ist.

⑤ **MΩ**
Leuchtet, wenn der MΩ-Bereich eingeschaltet ist.

VOLTS (Spannungen)

⑥ **DC (Gleichspannung)**
Taste zur Wahl der Meßfunktion „Gleichspannung“.

⑦ **AC TRUE RMS Wechselspannungseffektivwertmessung**
Taste zur Wahl der Meßfunktion Wechselspannung.

dBm/dBV 
Siehe Abschnitt Dezibel-Messung.

⑧ **dB**
Die Taste zur Wahl der Meßfunktion dB muß in Verbindung mit Taste ⑦ AC TRUE RMS betätigt werden. Die Referenz dBm oder dBV ist intern wählbar.

⑨ **kΩ**
Taste zur Wahl der Meßfunktion „Widerstand“.

⑩ **HI-LO**
Taste zur Wahl der Meßspannung im Widerstandsmeßbereich. Bei gedrückter Taste beträgt die Meßbereichsspannung 0,2 V in allen Bereichen, außer dem 20 MΩ-Bereich mit 2 V Meßspannung. Bei gelöster Taste beträgt die Meßspannung 2 V außer dem 200 Ω-Bereich mit 0,2 V Meßspannung.

⑪ **mA**
DC (Gleichstrom)
Taste zur Wahl der Meßfunktion Gleichstrom.

⑫ **INPUT EXT-INT (Externer/interner Eingang)**
Bei gelöster Taste sind die frontseitigen Eingänge zu verwenden. Bei gedrückter Taste der rückseitige Interface-Eingang für Gleich- und Wechselspannungs-, Widerstands- und Strommessungen.

⑬ **AC (Wechselstrom)**
Taste zur Wahl der Meßfunktion Wechselstrom.

VORSICHT

Die höchstzulässige Eingangsspannung an den frontseitigen Eingängen beträgt 1 kVs, an den rückseitigen Interfaceverbindungen 200 Vs.

Die gleichen Spannungen dürfen diese Eingänge maximal gegenüber Masse aufweisen, wenn das DM 502A auf hochgelegtem Potential arbeitet.

⑭ **TEMP °C**
Taste zur Wahl der Meßfunktion Temperatur in °C.

⑮ **mA**
Eingang für Strommessungen in Verbindung mit der allen Eingängen gemeinsamen Buchse LOW.

⑯ **LOW**
Allen Eingangsbuchsen entsprechender Bezugseingang – ausgenommen für Temperaturmessungen.

⑰ **TEMP**
Eingang zum Anschluß des Temperaturtastkopfes.



Abb. 2-2: Frontplattenbedienungselemente und -buchsen.

- 18 Masse**
Masseverbindungsbuchse, die mit dem Chassis des DM 502A verbunden ist.
- 19 VOLTS/ Ω**
Eingang für Spannungs- und Widerstandsmessungen mit dem Bezugseingang LOW.
- 20 AUTO (20 M Ω)**
Taste zur automatischen Bereichswahl bei Gleich- und Wechselspannungs- sowie dB- und Widerstandsmessungen. Der 20 M Ω -Bereich ist nur in der Betriebsart „Auto“ verfügbar.
- 21 Bereichswahl-tasten.**
Zur Wahl des gewünschten Meßbereichs ist die entsprechende Taste zu drücken.

Meßeingänge

Wird die mit INPUT (Eingang) bezeichnete Taste gedrückt (Position INT), sind die Meßsignale über die rückseitigen Interfaceeingänge einzuspeisen. Bei gelöster Taste (Position EXT) sind die Meßsignale den frontseitigen Eingangsbuchsen zuzuführen.

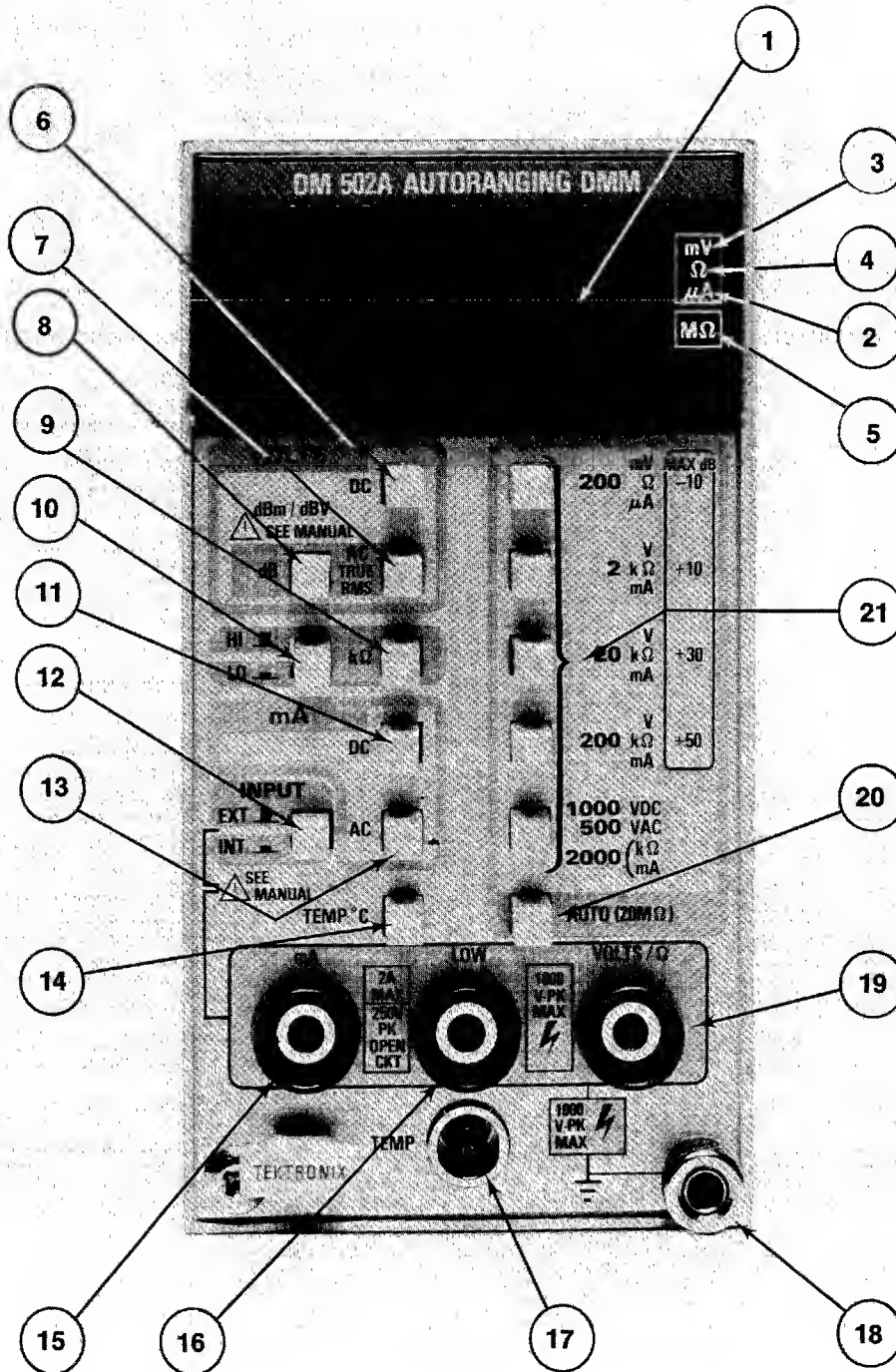
VORSICHT

Die höchstzulässige Eingangsspannung an den frontseitigen Eingängen beträgt 1 kVs, an den rückseitigen Interfaceverbindungen 200 Vs.

Die gleichen Spannungen dürfen diese Eingänge maximal gegenüber Masse aufweisen, wenn das DM 502A auf hochgelegtem Potential arbeitet.

Für die Einspeisung der Meßsignale stehen drei Buchsen zur Verfügung. Für alle Messungen, außer Strom- und Temperatur, werden die beiden mit VOLTS/ Ω und LOW bezeichneten Eingänge verwendet, wobei die LOW-Buchse nicht auf Chassispotential liegt. Zur Herstellung einer Massepotentialreferenz ist die LOW-Buchse mit der Chassismassebuchse zu verbinden. Hierbei ist zu beachten, daß die LOW-Buchse dann auf Schutzleiterpotential liegt und durch Bildung von Masseschleifen Fehlmessungen vorkommen können.

Durchführung von Messungen

Nach der Installation des DM 502A in eine TM 500-Versorgungseinheit ist zur Erreichung der Spezifikationen

eine Warmlaufzeit von ca. ½ Stunde zuzulassen. Nun ist die gewünschte Meßfunktion: Spannung, Dezibel, Widerstand, Strom oder Temperatur, und der Meßbereich oder Automatikbetrieb zu wählen. Der Auto-Betrieb arbeitet für alle Meßfunktionen – außer bei Strom- und Temperaturmessung.

Ist der Betrag des zu messenden Signals nicht annähernd bekannt, wählen Sie den Auto-Betrieb.

Die Meßeinheiten V, dB, k Ω , mA oder °C sowie μ A, mV, Ω oder M Ω werden auf der rechten Seite des Display dargestellt. Eine richtige Positionierung des Dezimalpunktes erfolgt automatisch. Zur Wahl des 20 M Ω -Bereiches ist die mit AUTO bezeichnete Taste zu drücken. Für Messungen ohne AUTO-Betrieb muß eine, dem Meßbereich entsprechende Taste gedrückt werden.

Die Darstellung der Meßeinheiten erfolgt in gleicher Weise wie im AUTO-Betrieb.

Gleichspannungsmessungen.

Hierzu ist die VOLTS DC-Taste und bei gewünschtem Automatikbetrieb die AUTO-Taste zu drücken. Bei Nichtautomatikbetrieb muß eine der entsprechenden Bereichstasten betätigt werden. Im Display erscheint ein + Zeichen, wenn die gemessene Spannung positiv gegenüber der LOW-Buchse ist, ein – Zeichen im umgekehrten Falle. Bei kurzgeschlossenen Buchsen zeigt das Display Null \pm 1 Digit.

Wechselspannungsmessungen

Die Taste VOLTS AC TRUE RMS ist zu drücken, sowie die AUTO-Taste oder eine der Bereichstasten. Die zu messende Spannung ist an die Buchsen VOLTS/ Ω und LOW anzulegen unter Beachtung der höchstzulässigen Eingangsspannung.

Dezibel-Messungen

Die Tasten VOLTS AC TRUE RMS und dB sowie die AUTO-Taste oder eine der Bereichstasten sind zu drücken. Die Anzeige erfolgt in dBm oder dBV abhängig davon, in welcher Position sich die intern angeordnete Brücke befindet. Die mit P1517 bezeichnete Brücke ist auf der Hauptplatine im oberen hinteren Viertel zu finden.

WARNUNG

Die Umstellung der internen Brücke ist nur von geschultem Personal vorzunehmen.

Zur Umrechnung von Spannungsverhältnissen in dB ist folgende Formel anzuwenden:

$$\text{dB} = 20 \log \frac{U_2}{U_1}$$

Ist das DM 502A auf dBV eingestellt, so ist die Referenzspannung $U_1 = 1 \text{ V}$, bei einer Anzeige von dBV. Bei der Einstellung auf dBm beträgt die Referenzspannung $0,7746 \text{ V}$ entsprechend 1 mW an 600Ω .

Widerstandsmessungen

Der zu messende Widerstand ist an die Buchsen VOLTS/ Ω und LOW anzuschließen und die Meßfunktionstaste k Ω sowie die entsprechende Bereichstaste zu betätigen. Wird eine automatische Bereichswahl gewünscht, ist die AUTO-Taste zu drücken. Widerstandsmessungen können in den Betriebsarten HI oder LO, wählbar an den damit bezeichneten Tasten, durchgeführt werden. Im LO-Betrieb beträgt die Meßspannung in allen Bereichen maximal $0,2 \text{ V}$ außer im $20 \text{ M}\Omega$ -Bereich mit 2 V Meßspannung. Im HI-Betrieb beträgt die Meßspannung in allen Bereichen maximal 2 V außer dem 200Ω -Bereich mit $0,2 \text{ V}$ Meßspannung.

Der LO-Betrieb eignet sich besonders zur Widerstandsmessung in halbleiterbestückten Schaltungen, da die Meßspannung von $0,2 \text{ V}$ unterhalb der Schwellspannung von Halbleitern liegt.

Strommessungen

Der zu messende Strom ist über die mit mA und LOW bezeichneten Buchsen zu führen, unter Beachtung des höchstzulässigen Wertes. Dann sind die Tasten mA und AC (bei Wechselstrommessungen) bzw. DC (bei Gleichstrommessungen) zu drücken. Bei Strommessungen verfügt das DM 502A nicht über eine automatische Bereichswahl.

Temperaturmessungen

Der Temperaturtastkopf P6601 ist an die mit TEMP bezeichnete Eingangsbuchse anzuschließen und die Taste TEMP °C zu drücken. Zur Erreichung der größten Genauigkeit ist das DM 502A mit dem entsprechenden Temperaturtastkopf zu kalibrieren. Nun ist der Temperaturfühler an das Meßobjekt zu halten.

Zur besseren Wärmeleitung ist es vorteilhaft, die zu messende Oberfläche mit Silikonpaste zu bestreichen. Vor der Auswertung ist eine angemessene Zeit zur Stabilisierung des Meßwertes zu gewähren. Die Zeit hängt von mehreren Faktoren ab. Im allgemeinen wird nach Anlegen der Meßspitze schnell ein stabiler Meßwert erreicht.

Mehr Information über Temperaturmessungen sind dem Handbuch des Temperaturtastkopfes P6601 zu entnehmen.

Verpackungshinweise

Sollte dieses Tektronix-Meßgerät einmal an eine Tektronix-Servicestelle geschickt werden, so legen Sie dem Gerät einen Anhänger mit Namen und Adresse des Besitzers, der Geräte-Serien-Nr. und der gewünschten Serviceleistung bei.

Bewahren Sie die Originalverpackung des Gerätes für evtl. Wiederverwendung auf. Steht diese nicht mehr zur Verfügung, verfahren Sie bitte wie folgt:

Das Gerät ist zum Schutze seines Äußeren mit Plastikfolie zu umwickeln, und in einen Karton aus Wellpappe mit genügender Festigkeit zu setzen. Die Innenmaße dieses Kartons sollten ca. 15 cm größer sein als die Geräteabmessungen. Polstern Sie das Gerät allseitig mit Styroporflöcken oder Schaum. Der Karton ist außen mit Verpackungsband zu umwickeln.

Die Festigkeit des Originalkartons beträgt ca. 14 kg/cm^2 .

取扱説明

取付および取はずし方法

DM502A型はTM500シリーズの本体に組込んで使用します。出荷時に校正されていますのですぐに使用できます。電源電圧については本体の取扱説明書をご覧ください。

注意

DM502A型を抜き差しする場合には本体の電源を切ってから行なって下さい。切らずに抜き差ししますと後部のインターフェイス・コネクタにアーキが生じ、コネクタの寿命を縮めるばかりでなく、中の回路にも悪影響を与えます。

DM502A型を本体に取り付ける前に、dBモードがdBm、dBVのいずれに内部ジャンパにより設定されているかお確かめ下さい。ジャンパ設定に関する詳細については、当社エンジニアにおたずね下さい。

本体のコネクタ内に入っているプラスチックの位置決めスペーサとDM502A型のエッジ・コネクタのカット部分とが一致していることを確認します。差し込もうとする本体のコンパートメントの上下のガイド(2-1図)に沿ってDM502A型を押し込み、さらに本体のコネクタにDM502A型のエッジ・コネクタがしっかりと固定されるまで押しして下さい。本体の電源をオンにしますとLEDが点灯します。DM502A型を取りはずす場合には、左下隅にあるつまみを引っぱりそのまま引き抜きます。

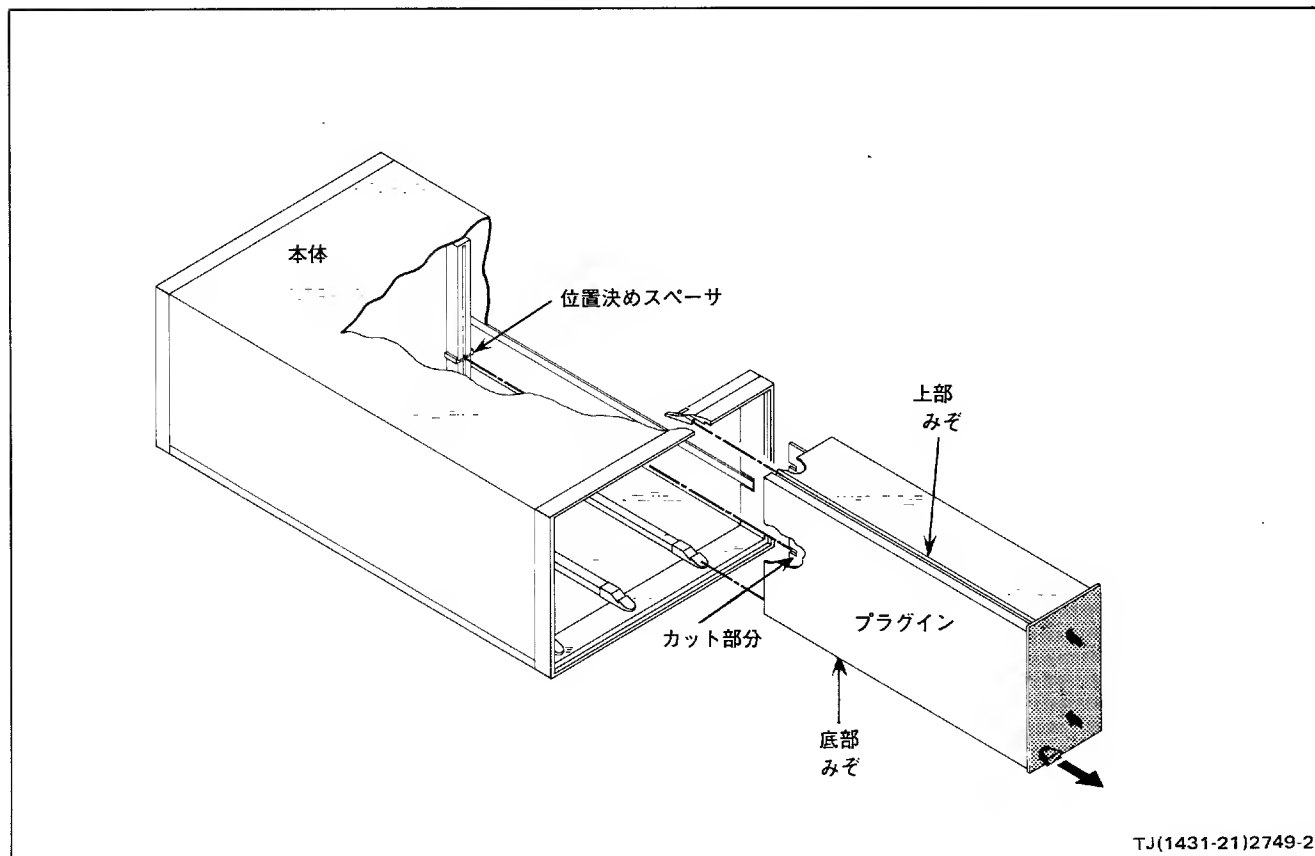

TJ(1431-21)2749-2

2-1図 取付および取はずし方法

コントロール、コネクタおよびインジケータ

DM502A型を操作するのに必要なすべてのコントロールコネクタおよびインジケータ（後部インターフェイス・コネクタとdBmとdBVのモード切替を行う内部ジャンパを除く。）は、フロント・パネルに配置されています。（2-2 図参照）

① 表示

3 1/2桁のLED表示、小数点は押しボタン・スイッチでレンジを切換えると自動的に移動します。

② μA

単位が μA の時点灯します。

③ mV

単位がmVの時点灯します。

④ Ω

単位が Ω の時点灯します。

⑤ M Ω

単位がM Ω の時点灯します。

VOLTS

⑥ DC

DC電圧測定用押しボタン・スイッチです。

⑦ VOLTS AC TRUE RMS

AC電圧測定用押しボタン・スイッチです。

dBm/dBV



2-4頁デシベル測定の項をご参照下さい。

⑧ dB

AC VOLTS TRUE RMS ボタンが押し込まれている時にこのボタンを押し込むとdBレンジが選択できます。

⑨ k Ω

抵抗測定用押しボタン・スイッチです。

⑩ HI-LO

抵抗測定の時を使用します。このボタンを押すとLO電圧が選択され、フル・スケール電圧は20M Ω レンジを除くすべてのレンジで0.2V、20M Ω レンジでは2Vになります。ボタンが押し込まれていない時はHI電圧となり、フル・スケール電圧は200 Ω レンジを除くすべてのレンジで2V、200 Ω レンジでは0.2Vとなります。

mA

⑪ DC

DC電流測定用押しボタン・スイッチです。

⑫

INPUT EXT-INT

このボタンが押し込まれていない時は前面パネル入力を選択されます。このボタンが押し込まれた状態の時はAC及びDC電圧、抵抗、電流測定に対してのみ後部インターフェイス入力を選択されます。

注意

最大入力電圧は、前面パネル・コネクタで1kVピーク、後部インターフェイス・コネクタで200Vピークです。前面パネルのVOLTS/ Ω 及びLOWコネクタは、グラウンドから最大1kVまでフローティングさせることができます。

⑬ AC

AC電流測定用押しボタン・スイッチです。

⑭ TEMP °C

温度測定用押しボタン・スイッチで、温度は摂氏で表示されます。

⑮ mA



電流測定用入力端子でLOW入力と共に使用します。

⑯ LOW



温度測定を除くすべての入力のコモン・コネクタです。

⑰ TEMP

温度プローブを接続します。

⑱ グラウンド端子

シャーシ・グラウンドです。

⑲ VOLTS/ Ω 

電圧及び抵抗測定の際にLOWコネクタと共に用います。

⑳ AUTO (20M Ω)

DC、AC電圧、dBおよび抵抗測定の時、オート・レンジ切替となります。20M Ω レンジでの測定はこのモードでのみ可能です。

㉑ レンジ・セレクタ押しボタン・スイッチ

これらの5つの押しボタン・スイッチで測定レンジを選択します。

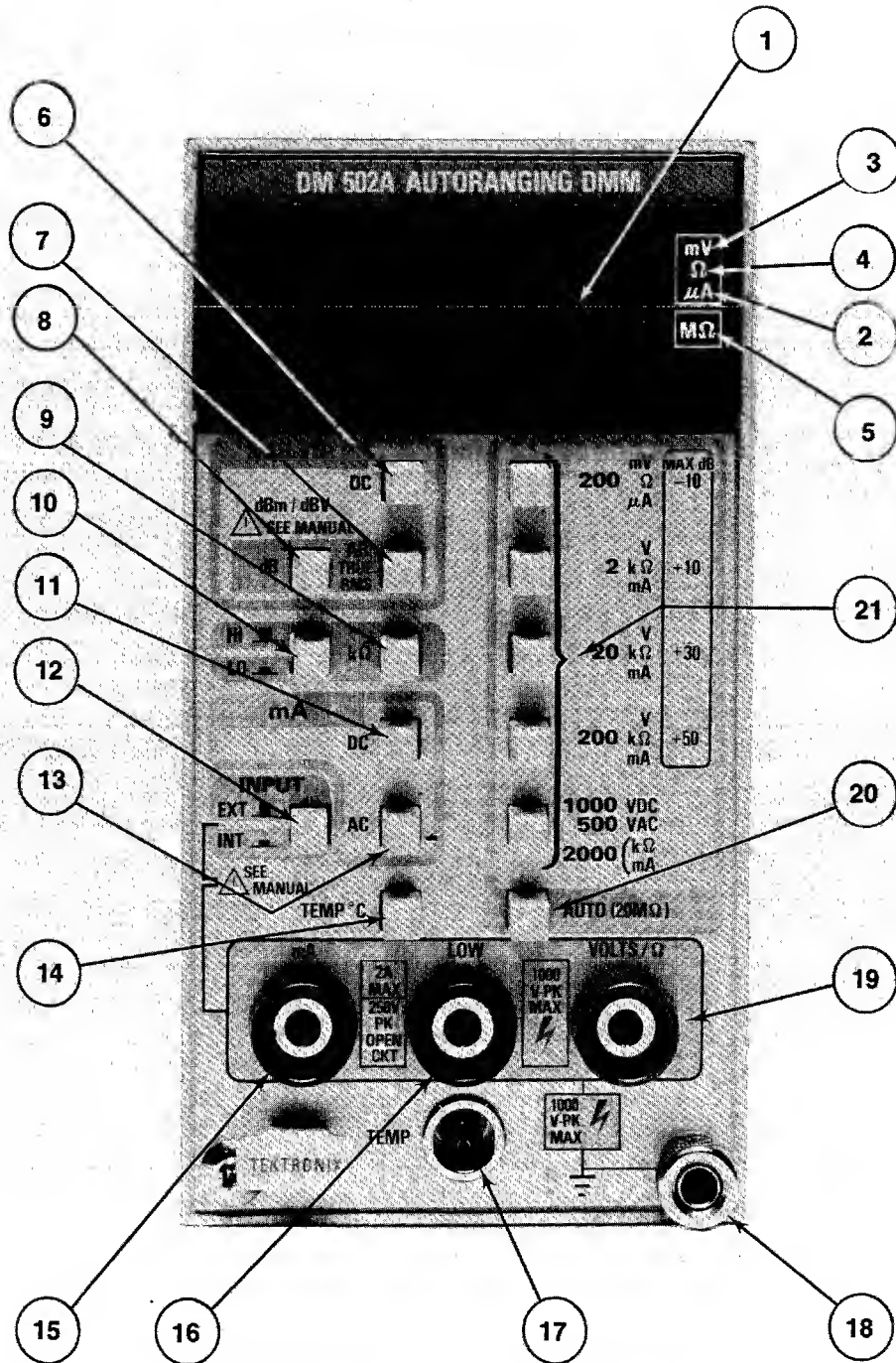

2-2図 コントロールとコネクタ

入力との接続



INPUT ボタンが押されている時(INT)は、入力信号は後部インターフェイス・コネクタを通して入力されます。INPUT ボタンが出ている時(EXT)は、前面パネル・コネクタを通して入力されます。

注意

最大入力電圧は、前面パネル・コネクタで1kVピーク、後部インターフェイス・コネクタで200Vピークです。前面パネルのVOLTS/ΩとLOWコネクタでは、グランドから最大1kV、後部入力コネクタでは200Vまでフローティングさせることができます。

3つの入力コネクタは測定信号の接続に用いられます。VOLTS/Ω及びLOW入力コネクタは電流及び温度を除くすべての測定に用いられます。通常の測定では、LOWコネクタと測定回路のコモンとを接続します。LOWコネクタとGND入力端子との接続はDM502A型のシャーシ・グランドと入力との比較が表示されます。本体の3線電源コードを通してLOWコネクタがアース・グランドに接続されている場合にはグランド・ループにより誤った測定値が表示されることがありますので注意が必要です。

機能説明

DM502A型は本体に組み込んで電源をオンにした後、30分の子熱時間で仕様の精度を満足します。希望の測定項目とレンジまたはオート・レンジ切替モード(AUTOモード電流と温度測定の場合は除く。)を選択しますが、測定しようとする値が不明の時には最初AUTOモードで測定します。表示行のmV、μA、Ω、MΩが点灯しない場合には、V、dB、kΩ、mAのいずれかの単位で測定値が表示されています。小数点は自動的に位置決めされます。20MΩレンジを使用するにはAUTO(20MΩ)のボタンを押します。オート・レンジ機能を必要としない場合は、レンジ・セレクト・ボタンより希望のレンジを選択します。測定単位はオート・レンジの時と同様に指示されます。

DC電圧測定

VOLTS DC ボタンを押しAUTO、または適切なレンジを選びます。測定しようとする電圧をLOWとVOLTS/Ωコネクタに入力します。前面パネルに書かれている最大入力定格電圧にご注意下さい。LOW入力コネクタに比べてVOLTS/Ωコネクタに加わる電圧が大きい場合にはリードアウト表示は+になります。逆の場合には-になります。LOWとVOLTS/Ω入力コネクタをショートさせるとリードアウト表示は谷になります。

AC電圧測定

VOLTS AC TRUE RMS ボタンとAUTO、または適切なレンジを選びます。測定しようとする電圧をLOWとVOLTS/Ωコネクタに入力します。その際最大入力定格電圧に注意します。

デシベル測定



VOLTS AC TRUE RMS ボタンとAUTOまたはレンジ・セレクト・ボタンを押しレンジを選びます。DM502A型では、dBmまたはdBV(内部ジャンパで切替)が直読できます。ジャンパは後部のメイン・ボード上にあり、PI517と番号表示されています。

注意

ジャンパの切替については当社エンジニアにおたずね下さい。

電圧とデシベルの関係式は

$$\text{dB} = 20 \log_{10} \frac{E_2}{E_1}$$

DM502A型がdBVにセットされている時は、関係式の基準電圧(E_1)を1Vとして、dBVで計算結果が表示されます。ジャンパがdBmにセットされている場合は、基準電圧が0.7746Vとなります。これは600Ωの負荷で1mW電力が消費されることを意味します。 E_2 は未知の電圧となります。

抵抗測定

測定する抵抗をVOLTS/ΩとLOW入力コネクタに接続します。適当な測定レンジを押しボタン・スイッチで選ぶか、またはオート・レンジ機能を使用する時はAUTO押しボタン・スイッチを押します。測定端子間に加えたい電圧に応じてHIまたはLO電圧を選択します。LO電圧を選択した場合は、20MΩレンジを除くすべてのレンジで0.2V、20MΩレンジでは2.0Vかかります。HI電圧を選択した場合には、200Ωレンジを除くすべてのレンジで、2.0V、200Ωレンジでは2.0Vかかります。HIにした時の特長はノイズや熱電対(異種の金属接合)によって生じる誤差に影響されないことです。LOの場合には、ほとんどのシリコン型半導体素子に対してフォワード・バイアスすることなしに、インサーキット測定ができます。

電流測定

測定すべきACまたはDC電流をmAとLOWコネクタに接続します。その際、最大入力定格電圧に注意します。mAおよびDCまたはACボタンを押し電流レンジを選択します。DM502A型は、電流モードに関してはオート・レンジ作動しません。

温度測定

前面パネルのTEMPコネクタに**P6601型**温度プローブを接続します。接続ピンに注意して差し込んで下さい。TEMP°Cボタンを押し、プローブの先端のチップを測定したい場所に接触させます。より精確に温度を測定するには、被測定物の表面にシリコン・グリスを塗ってから、プローブ・チップをあてます。値を読取る前に、先端のチップの温度が十分安定するまで時間をかけて下さい。安定するまでの時間は、プローブと測定物(DUT)の熱容量および熱抵抗、DUTに与えられた熱の合計によって変わってきます。温度測定とプローブの使用方法についての詳しい説明は**P6601型**の取扱説明書をご覧ください。標準付属品（および部品番号）についてはメカニカル・パーツ表に記載されています。

梱包方法

納入時に機器が梱包されていた箱を使用すれば簡単に再梱包ができますが、もしその箱がない時には次のように行なって下さい。

機器の塗装を保護するためにポリエチレン・シートのような物でくるみます。機器の長さよりも15cm位長い丈夫なダンボール箱を用意し、その箱の中にウレタン・フォームのようなクッション材を、上下左右に均等に箱と機械のあいだに詰めます。箱をテープもしくは大型ホチキスでシールします。この機器については15kg/cm²以上の箱の強度があれば充分です。

THEORY OF OPERATION

Introduction

The DM 502A is an analog-to-digital converter with the input circuits, logic, display devices, and power supplies necessary to display, in digital form, the value of an input voltage, current, resistance, or temperature. The analog-to-digital converter is an integrating amplifier (analog processor) controlled by digital circuitry. Refer to the block diagram in the foldout pages for an overall view of the DM 502A operation.

Voltage and dB Input Circuitry

Input from either the front panel VOLTS/ Ω and LOW connectors or the rear interface input is selected by S4. In all modes except temperature, the LOW input connects to the analog board floating ground. Voltage applied to the VOLTS/ Ω connector passes through S1-C and S1-B to the junction of R1118C and R1218. The attenuator is composed of three resistors, R1118A, B, and C. In all modes except resistance, R1118A is connected to the floating ground on the analog board through S1-C. The desired attenuation is selected by relays K1114, K1115, and K1216 (see Table 3-1). Input to ac buffer amplifier U1013 is ac coupled through C1401. The attenuator is ac compensated by C1213, C1215, and C1212. The dc voltage passes through DS1014, S1-E, S1-D, S1-B, S1-F, and R1416 to pin 15 of the analog-to-digital converter, U1461, shown on schematic 2.

In the ac voltage mode, C1401 is connected in series with the attenuator, as previously described. The attenuated ac voltage is applied to pin 3 of U1013. The gain of this operational amplifier is either 1 or 10 as determined by the position of K1113. When R1113 is grounded (through S1-C and K1113) the gain is 10. The ac signal passes from pin 6 of U1013 to pin 1 of U1205, a true rms-to-dc converter. This converter chip computes the root-mean-square level of the ac input signal and gives the equivalent dc output level from pin 8. This dc output connects to the input of the analog-to-digital converter, U1461. The dB conversion also takes place in U1205. The output at pin 5 (-3 mV/dB) is applied to pin 7, the plus input of a unity-gain buffer amplifier contained in U1205. The dc output voltage from the buffer output at pin 6 is applied to the negative input of three operational amplifiers, U1004B, U1025A, and U1015 (located on schematic 2). Appropriate dB scaling current from U1501 is applied to the junction of R1107 and pin 6 of U1004B. This current, when added to the dc current from the buffer output at pin 6 of U1205, provides the correct output voltage at pin 7 of U1004B for the dB range selected.

The output from U1004B, pin 7, is applied to the analog-to-digital converter input in the dB mode via the appropriate switches. When the dB output voltage at pin 2 of U1025A goes sufficiently negative, determined by the setting of R1024, pin 1 of U1025A goes to a TTL high, indicating dB overrange to the autoranging circuitry. Pin 7 of U1025B goes high when the buffer output from the true rms converter is underrange, as determined by the setting of R1012.

Ohms Converter

The current setting resistances connect from the output to the plus input terminal of U1013, an operational amplifier. These are the same resistances used for voltage attenuation, as previously described. The voltage developed across the external unknown resistance is applied between the plus terminal of U1013 and floating ground. Negative feedback occurs from the output of U1013 to the negative input terminal. The gain of U1013, when used in the resistance mode, is reduced by a factor of 10 when R1113 is added (through S1-C and K1113) to the negative feedback loop. When the HI-LO button is pushed R1113 is connected in the circuit via K1113, pins 1 and 4. Current reference for this circuitry (1 mA) is provided by Q1301 in conjunction with VR1303. Calibration for U1013 in the resistance mode is provided by R1306.

The purpose of the ohms converter is to provide constant current, within the measurement range selected, to the unknown resistance. The voltage drop across the unknown resistance is applied to pin 3 of U1013. This voltage drop is applied directly to the input of the analog-to-digital converter (U1461) and displayed as a resistance value.

Temperature Measurement Circuitry

Temperature is measured by passing a 1 mA constant current through a resistance in the temperature probe (the resistance varies with temperature) and measuring the voltage drop across this resistance. Constant current (1 mA) for the temperature probe is supplied by Q1301. The voltage is applied to pin 2 of U1004A. Voltage offset that would cause a zero temperature error is balanced out by R1001. The gain of amplifier U1004A is set by R1002. Output from the temperature amplifier is taken from pin 1 and applied through the appropriate switching to the input of the analog-to-digital converter.

Table 3-1 RELAY AND ATTENUATOR (Q1472) LOGIC

RELAY AND Q1472 LOGIC		RELAY					Q1472	
		K1113	K1114	K1115	K1216	K1442		
DC VOLTS	200 mV	X			●	●		
	2 V	X			●			
	20 V	X		●		●		
	200 V	X		●				
	1000 V	X	●					
AC VOLTS/dB	200 mV	●			●			
	2 V				●			
	20 V	●		●				
	200 V			●				
	500 V			●			●	
DC mA	200 μ A	X	X	X	X	●		
	2 mA	X	X	X	X	●		
	20 mA	X	X	X	X	●		
	200 mA	X	X	X	X	●		
	2000 mA	X	X	X	X	●		
AC mA	200 μ A	●			X			
	2 mA	●			X			
	20 mA	●			X			
	200 mA	●			X			
	2000 mA	●			X			
K Ω	200 Ω	HI		●			●	
		LO		●			●	
	2 K	HI		●				
		LO			●		●	
	20 K	HI			●			
		LO	●		●		●	
	200 K	HI	●		●			
		LO				●	●	
	2000 K	HI				●		
		LO	●			●	●	
	20 M	HI	●			●		
		LO	●			●		
TEMP		X	X	X	X			

Open
Closed
Condition does not affect operation

●	●	X

2693-4

Current Measurement Circuitry 1

Currents to be measured are applied through the front panel mA and LOW connectors. The current flows through a protective fuse (F1017) and through the appropriate current shunt resistors as selected by the current range switches, S2-B through S2-E. The voltage drop across shunt resistors R1041A through C, R1058, and R1151, is applied directly to the analog-to-digital converter in the dc mode. The voltage drop across the shunt resistors in the ac mode is applied through appropriate switching to amplifier U1013 (X10 gain), to pin 1 of the true rms converter and then as a dc signal to the analog-to-digital converter.

Analog-to-Digital Converter 23

The converter (see the Block Diagram for Analog-to-Digital Converter) in the DM 502A operates on the charge balancing principle. The net charge put into an integrator over one integration cycle is zero. This converter has no fixed charging period. The charging continues for as long as necessary to get the capacitor voltage to cross a fixed threshold level. A reference current is subtracted from the input current and the capacitor discharges until the threshold level is crossed again. The process repeats until the conversion period is over. A counter, which only accumulates clock pulses when both the input signal and the reference current are applied to the capacitor, contains a number of counts proportional to the input voltage.

Auto Zero Interval 23

Referring to Fig. 3-1, during the auto zero (AZ) interval the offset voltages generated in the internal amplifiers are nulled. A tracking reference voltage is automatically established. This voltage is necessary for bipolar conversion. The auto zero sequence is initiated when the measure-zero (M/Z) signal from U1311 switches the input buffer amplifier to ground. After a brief count correcting override period, the auto zero amplifier and integrator are connected together. During this time, the control logic in U1311 ignores the comparator output and pulses the internal up-down switch of U1461 at a 50% duty cycle (4 clock periods up and 4 clock periods down). Equilibrium of this system is attained when the average currents through R1458, R1443, and R1455 are equal and opposite. The auto zero voltage is thus established and stored on C1562. This is approximately -1 V and is noted on Fig. 3-1. This auto zero voltage stored on C1562 establishes a reference voltage for the up-down (U/D) logic to switch either a plus or minus reference current to the integrator during conversion. When the up-down line (U1461, pin 4) is high, the reference voltage is positive. The auto zero time interval is sufficient to ensure that the auto zero voltage is well established.

Converter U1461 is gain switched by relay K1442. The gain is sufficient for a 200 mV full scale reading with the relay energized or 2 V full scale with the relay off. The 2 V full scale reading is adjusted by R1443 and the 200 mV full scale reading is adjusted by R1531. The auto zero filter is composed of R1454 and C1562. Additional offset charge is supplied during the auto zero interval from the measure-zero line, (U1311, pin 10), through Q1553 and C1553. Reference voltage for U1461 comes from a 6.2 V Zener diode, VR1565.

Measurement Interval 23

The digital control logic in U1461 feeds units of charge (controlled by an analog comparator) to the integrating capacitor, C1432. This charge balances the charge supplied to the integrator by the analog input voltage. The sign of the charge fed back depends on the two up-down duty cycles available during the measurement interval as shown in Fig. 3-1. The comparator output is high when the charge on C1432 is above approximately -1 V and low when the charge is below approximately -1 V. The clock for the converter is generated by U1611. Potentiometer R1523 is adjusted for a frequency of 20.48 kHz. The up-down logic is high for 1 clock cycle and low for 7 clock cycles for a high comparator output in the clock cycle preceding the set of 8 cycles just described. This is designated duty cycle A. When the comparator output is low in clock cycle 7, the up-down logic is high for 7 cycles and low for 1 cycle during the 8 clock cycles following duty cycle A. This is shown as duty cycle B. The bottom waveform in Fig. 3-1 shows the effect of these two reference current duty cycles on the integrator output (pin 11 of U1461). When the up-down logic is in the high state (duty cycle B), the integrator output voltage rises. The bcd counter in U1311 increments by each clock pulse when the up-down logic is high and decrements by each clock pulse when the up-down logic is low. The net count increases by 6 counts for the B duty cycle and decreases by 6 counts for the A duty cycle.

Input polarity is determined by the first appearance of two consecutive duty cycles of the same type. The control logic determines the analog input as negative if two A duty cycles occur in succession and positive if two B duty cycles occur in succession.

A short override interval is provided at the end of the measurement cycle (M/Z goes low) to tune the count to the nearest least significant bit. This occurs within the first 32 clock periods of the auto zero interval. The contents of the bcd counters and the sign information are loaded into the internal latches following the override sequence. Counter accumulations less than 100 or greater than 1999 are decoded as underrange or overrange information, respectively.

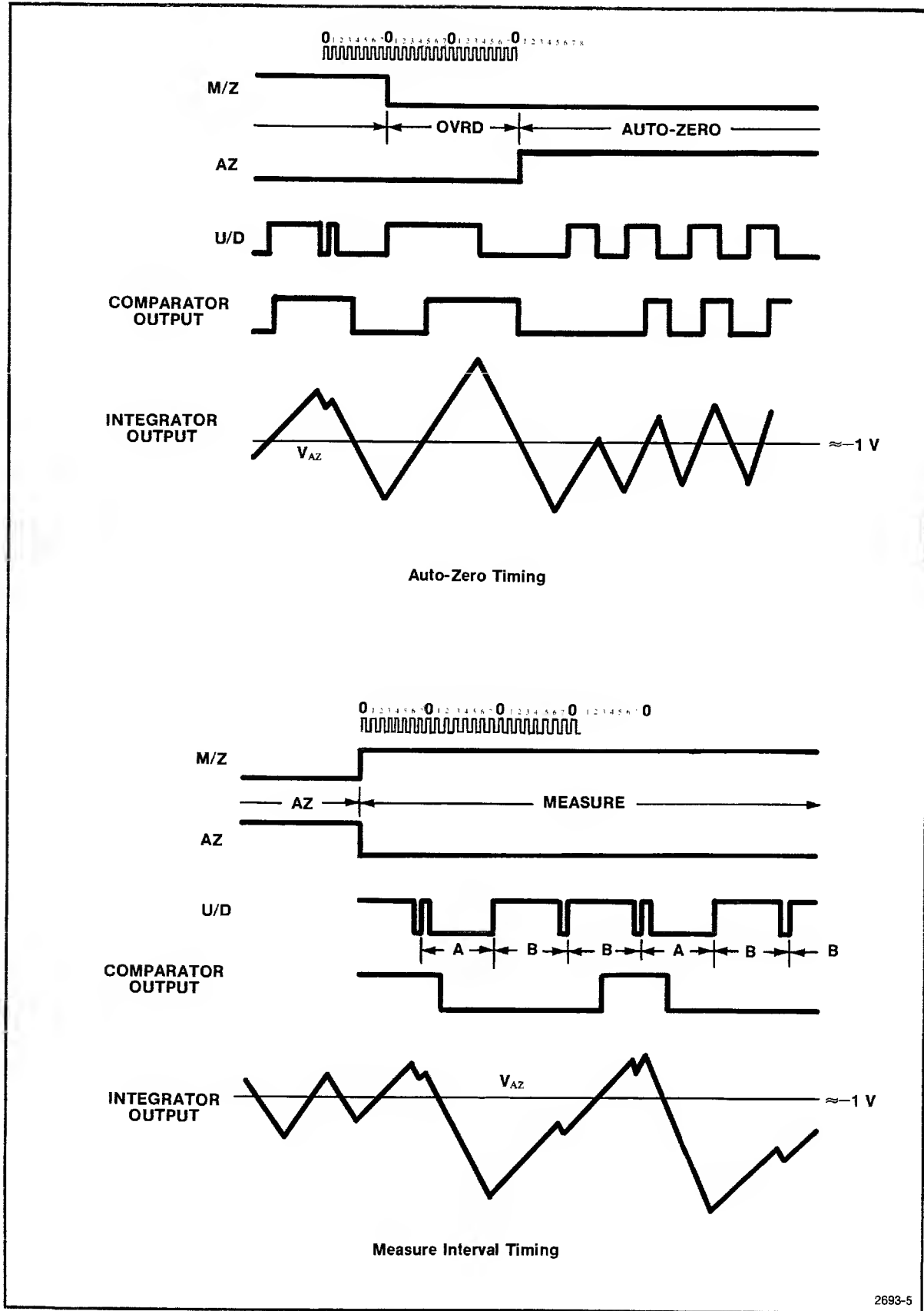

Fig. 3-1. Auto-zero and measurement interval timing sequences.

The underrange signal is impressed on bit 4 during D4 time. The overrange signal blanks the display during the auto zero interval. Overrange information to U1321 is provided when all time slot lines go low causing a high on pin 8 of U1301A. The time slot lines are pins 1, 2, 3, and 4 of U1311. Pin 8 of U1301A alternates high and low during overrange at the measure –zero rate (display blinks).

The bcd data stored in the latches is scanned every 32 clock periods (8 clock times per digit). Figure 3-2 shows the output data format for U1311. Sign information appears on pin 5 with a high for positive and a low for negative. All outputs are active in the high state.

The input to the analog-to-digital converter, pin 15 of U1461, is attenuated by a factor of 10, when operating in the 500 V range, through R1466, C1561, and Q1472. This attenuator is also activated during some range changes when in AUTO mode, to shorten the discharge time of the auto zero filter. When the base of Q1456 is low, FET Q1472 conducts, placing the attenuator from the input to ground.

The bcd information from U1311 (see Fig. 3-2) is fed to the inputs of U1201, a bcd to seven segment decoder driver. The outputs of U1201 are connected in parallel to all of the display modules except the most significant digit. The digits are scanned in a 1, 3, 2, 4 sequence from pins 1, 2, 3, and 4 of U1311. These four lines are connected to inverters U1211A, B, C, and D, which in turn drive transistors that supply +5 V to the anodes of the display modules. The current for the sign is supplied by Q1105 and the cathode is pulled low via U1211E. Logic information on P1221, pin 10, blanks the sign when ac volts, ac current, or resistance is selected. When the sign is activated, the base of Q1105 is asserted low. Transistor Q1105 conducts, supplying current to the segments in the most significant digit module. The sign appears when dc volts, dc current, dB, or temperature is selected.

Decimal Point Logic 3

The decimal point cathodes are grounded via U1361C and R1119 during the appropriate time slot. Time slot 2 feeds to pin 1 of U1421A. Timeslot 3, corresponding to the second most significant digit, is fed to pin 9 of U1431B. Time slot 4 feeds pin 2 of U1431A. The other inputs for U1231C, U1431A, U1431B, and U1331D go low when a particular range is selected. The input lines are labeled on the schematic according to their logic function.

When ac volts, dB, or temperature mode is selected, pin 11 of U1431B, pin 13 of U1431A, and pin 9 of U1231C are low. This action locks out U1431A and U1431B and places a high at pin 8 of U1231C. When time slot 2 is scanned, pin 1 of U1421A goes high. This causes a low at pin 3 of U1431C, and consequently, the decimal point lines to the display modules are low only when the second most significant digit is scanned. This places the decimal point in the proper position. There is no active decimal point line for the 1000 V dc, 500 V ac, 2000 k Ω , and 2000 mA buttons as there is no decimal point in the display when these buttons are pressed. When the 20 M Ω range is selected, pin 12 of U1331D goes low. This action illuminates the 20 M Ω LED, DS1102, during the fourth time slot. The cathode is pulled low through R1132. The low on pin 12 of U1331D causes pin 11 of U1331D to go high. In the resistance mode, pin 11 of U1431B is high. During the third time slot pin 9 goes high causing pin 8 of U1431B to go low. This action illuminates the decimal point in the second most significant digit module. If the top most measurement range pushbutton is pressed (200 mV, Ω , μ A), pin 10 of U1231C goes low. This illuminates the appropriate LED, DS1101, on the front panel and causes a high at pin 2 of U1421A. When the second time slot is scanned, pin 3 of U1421A goes low and, as previously described, the decimal point is illuminated in the second least significant digit module.

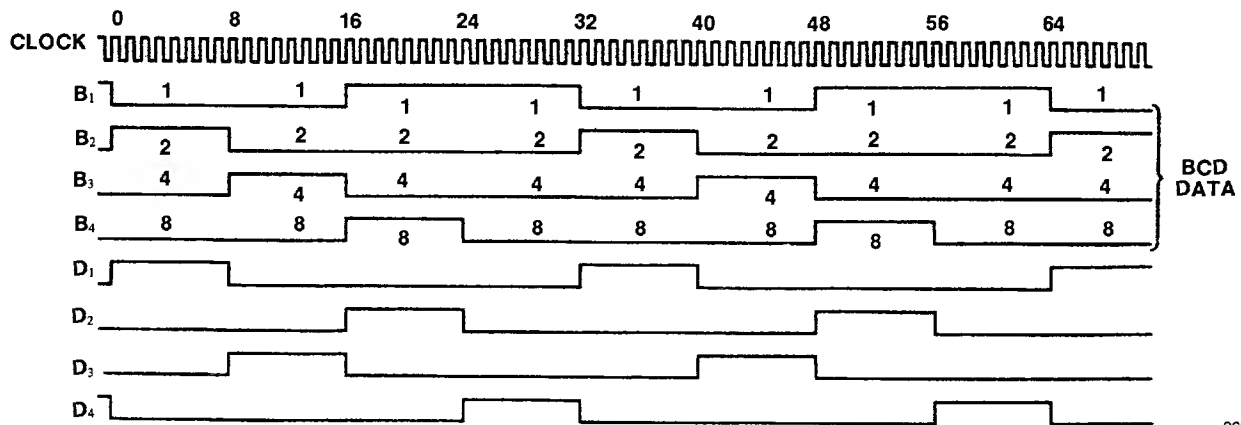

Fig. 3-2. Data output format from U1311 for a display of 1492. The most significant digit is D4.

Auto Ranging Circuitry 

A decade counter (U1146) provides, through various logic gates, the necessary signals to open or close the various relays in the attenuator circuits. Overrange information from U1321 provides a negative to positive transition at the clock input, pin 14 of U1146, each time overrange information is presented at the input of U1321. The counter, U1146, is reset to zero whenever pin 6 of U1321 goes low. This action causes a high at pin 15 of U1146. Pins 9, 10, and 11 or pins 1, 13, and 12 of U1321 must be high to cause U1146 to increase by one count. For example, when the dB and VOLTS AC TRUE RMS pushbuttons are pressed, pin 9 of U1221A is low. This causes pin 11 of U1321 to be high. Pin 9 of U1321 goes high when the dB input voltage is overranged. The dB overrange and underrange circuitry was described under Measurement Interval. With pin 8 of U1221A high, pin 3 of U1301B is also high. A high exists on pin 5 of U1301B during overrange conditions. This high enables U1301B and pin 6 is low. This action causes a high on pin 11 of U1421D enabling U1421C. As the measure-zero (M/Z) line from U1311 alternates high and low for the measure interval timing and auto zero timing, pin 9 of U1421C follows. Pin 8 of U1421C goes high and low at the measure-zero rate which in turn causes pin 10 of U1321 to alternate at the same rate. As pin 10 of U1321 alternates high and low (with pins 9 and 11 of U1321 high), pin 8 of U1321 also transits from high to low. This causes pin 14 of U1146 to step low to high. The count output from U1146 increases by one for each clock transition. As pin 8 of U1421C alternates high to low, the display is flashed via pin 4 of U1201, the seven segment decoder driver. The display blinks, indicating overrange or underrange, via internal circuitry in U1311 through the time slot lines (pins 1 through 4 of U1311) in all modes except dB overrange and underrange (underrange in all ranges except the lowest) and ac or dc current when in the automatic mode. Under these exceptions the display is caused to blink through pin 4 of U1201. When the unit is not in the ac volts and dB mode, pin 12 of U1321 is high. Overrange information from U1301A is also high (pin 13 of U1321). This causes a high to low transition at pin 8 which in turn steps the counter one count.

A high to low transition on pin 6 of U1321 causes a high on pin 15 of U1146 which resets the counter to zero. This action occurs with highs on pins 4 and 5 (or pins 3 and 2) of U1321. Pin 5 of U1321 is high as determined by the dB underrange circuitry. Pin 4 is high when in the ac volts and dB modes. Pin 10 of U1136D is high when the most significant digit is illuminated. Pin 9 is high when the fourth binary bit at pin 13 of U1311 is high. This causes a high on pin 2 of U1321 which results in a low at pin 6.

Power-up reset occurs through U1126D. When power is first applied, pin 11 is high. This causes pin 13 to go low, which causes a high on pin 15 of U1146, resetting the counter to zero.

When pin 12 of U1411C is low, the 10X attenuator at the input to the analog-to-digital converter is connected in the circuitry. This occurs when pin 13 or pin 2 of U1411C is high. For U1411A, when the overrange condition is true (pin 10 low), the auto mode condition exists (pin 9 low), and when any range other than the 20 M Ω range or the 2000 range (for any function other than ohms) is selected (pin 11 low), pin 8 will be high. The 10X attenuator is also activated when pin 5 of U1441B is low (500 V ac volts mode) and when pin 4 is low (ac volts and dB mode).

When the unit is in the resistance mode, pin 5 of U1136B and U1421B is low. This action disables these gates. In any mode other than resistance, pin 5 of these gates is high. When the 2000 range is activated, pin 4 of the U1136B goes high. This causes pin 6 to go low forcing pin 13 of U1146 high, disabling the clock input at pin 14 and preventing any range higher than the 2000 range. If, however, the unit is in the resistance mode, U1136B is disabled and the clock input is no longer disabled in the 2000 range. In the 20 M Ω range, which is reached only in the automatic mode, pin 12 of U1156A is low. This forces pin 3 of U1136C high disabling the clock input of U1146 and preventing the range count from exceeding the 20 M Ω range. The carry out signal, pin 12 of U1146, goes low between the 4th and 5th counts. This low on pin 12 ensures a high on pin 4 of U1421B. If the unit is switched from the resistance mode, pin 6 of U1421B goes low. This low causes a high at pin 15 of U1146 and resets the counter to zero. This is necessary as the fifth count in any mode other than AUTO is illegal.

Relay Switching Circuitry 

As previously described, U1146 will increase the count output until the analog-to-digital converter outputs a count greater than 99 and less than 2000. The count output from pins 3, 2, 4, 7, 10, and 1 pass through inverters. The signals then pass through S2-F, the AUTO range switch. If the auto mode is not selected, the inputs to inverters U1166A through E are connected to the manual range select switches, S2-A through E. The range is selected when the manual switch wiper contact is grounded and disabled when the wiper is connected to +5 V. The output from either inverters U1156A through F or the manual range select switches connects to the input of inverters U1166A through E. Their outputs are logically ANDed to the various range select lines, as labeled on the schematic, which drive the relay drivers U1361A through E. The logic to the AND-OR gate circuitry driving the relay drivers is apparent from the lines labeled on the schematic. When the output of U1361A is low, the attenuator is in the 1X position. When pin 15 of U1361B is low, the attenuator is in the 100X position. When pin 14 of U1361C is low, the attenuation is 1000X. When pin 13 of U1361E is high the analog-to-digital converter is in the 200 mV full-scale mode, and when low, the converter is in the 2 V full-scale mode. With pin 12 of U1361D low, the gain of U1013 is unity.

dB Offset Current Source 

Offset current is provided at pin 6 of U1004B, in the dB mode, to provide proper scaling factors. This current is supplied via two sources. The first is a negative current from the -12 V supply through R1512, R1518, and R1418. This current is the only offset current when in the $+40$ dB range. Using variable resistor R1518, adjustment of the negative current source is done in the $+40$ dB range. The second is a positive current source derived from the $+15.75$ V supply and a divider composed of R1521 and R1515. This source is connected to three equal resistors, R1416, R1514, and R1516. These three current sources are controlled by a quad-bilateral switch, U1501. When the .2 range (-10 dB) is selected, maximum offset current is supplied (U1401A, B, and C are enabled). When the 2 range ($+10$ dB) is selected, U1401A and U1401B are enabled reducing the offset current by one third. In the next higher range, the 20 range ($+30$ dB), U1401C is enabled and the current is reduced to one-third the maximum value. The additional dB ranges require no

external offset current. The dB Reference current is adjusted by R1518. R1418 is shorted by P1517 to slightly increase the dB scaling current for the dBm mode.

Power Supplies 

The 25 V ac is supplied from the power module through rear interface pins 13A and 13B to the primary of T1721. The correct ac output voltage at pin 7 and 9 of T1721 is bridge rectified and applied to two three-terminal regulators, U1655 for the $+15.75$ V and U1754 for the -12 V. The normally grounded reference point for U1655 is raised slightly above ground by R1771. This raises the output of U1655 by 0.75 V. The ac voltage at pins 10 and 12 of T1721 is full-wave rectified and applied to a three-terminal regulator, U1651. The output of this regulator is $+5$ V. All three-terminal regulators are internally current limited. Zener diode VR1451 supplies $+12$ V from the $+15$ V supply.

CALIBRATION

PERFORMANCE CHECK

Introduction

This procedure checks the Electrical Performance Requirements as listed in the Specification section in this manual. Perform the internal adjustment procedure if the instrument fails to meet these checks. In some cases, recalibration may not correct the discrepancy; circuit troubleshooting is then indicated. Also, use this procedure to determine acceptability of performance in an incoming inspection facility. For convenience, many steps in this procedure check the performance of this instrument at only one value in the specified performance range. Any value within the specified range, within appropriate limits, may be substituted.

To check the rear interface accuracy specifications, access the rear interface pins 28A (LO) and 28B (HI) with an Option 2 power module. Instructions and accuracy tables for rear interface performance checks are given following this procedure.

Test Equipment Required

The following test equipment, or equivalent, is suggested to perform the Performance Check and the Adjustment Procedure.

Table 4-1
TEST EQUIPMENT

Description	Minimum Specifications	Purpose	Examples of Applicable Test Equipment
Dc voltage source	0 V to 1 kV within $\pm 0.01\%$.	Dc voltmeter check. Adjust 2 V and 0.2 V ranges.	Fluke Model 341A Voltage Calibrator
AC voltage source	0 V to 500 V rms, 40 Hz to 20 kHz within $\pm 0.05\%$.	Ac voltmeter and dB check. Ac gain adjustment. Ac comp adjustment. dB zero adjustment. -20 dB adjustment. dB gain adjustment. Overrange adjustment. Underrange adjustment.	Fluke Model 5200A Ac Voltage Calibrator and Fluke Model 5215A Power Amplifier
Resistance standard	0 Ω to 20 M Ω within $\pm 0.05\%$.	Ohmmeter check. Ohms adjustment.	Electro Scientific Industries Model DB 62 Decade Resis- tance Box
Dc current source	0 A to 2 A within $\pm 0.02\%$.	Dc ammeter check.	Valhalla Scientific Inc. Model 2500 Ac-Dc Current Calibrator
Ac current source	0 A to 2 A, 40 Hz to 10 kHz, within $\pm 0.06\%$.	Ac ammeter check.	Same as for dc current.
Digital Counter ^a	Capable of measuring 20.48 kHz, within 0.25%.	Check clock frequency.	TEKTRONIX DC 504 Digital Counter ^b

Table 4-1 (cont)

Description	Minimum Specification	Purpose	Example
Digital Multimeter ^a	0 V to +20 V with 1 mV resolution.	Adjust power supply. Amplifier zero adjust. dB zero adjustment.	TEKTRONIX DM 501 ^b
1X Probe ^a		Connect counter to test points.	TEKTRONIX P6101 1X Passive Probe
1 ea. bnc female to dual banana adapter		Connect coaxial cable to instrument under test.	Tektronix Part No. 103-0090-00
1 ea. coaxial cable with bnc connectors		Connect test equipment to DM 502A.	Tektronix Part No. 012-0057-01
1 ea. bnc male to dual binding post		Common mode rejection check.	Tektronix Part No. 103-0035-00
1 ea. female bnc to clip leads		Common mode rejection check.	Tektronix Part No. 013-0076-00
1 kΩ resistor	1% tolerance, 1/8 watt.	Common mode rejection check.	Tektronix Part No. 321-0193-00
Dual banana shorting bar		Short input terminals.	Tektronix Part No. 134-0012-00
Flexible extender ^a			Tektronix Part No. 067-0645-02 ^b
Temperature bath	-55°C to +200°C within ±0.25°C.	Temperature probe check and adjustment.	Neslab Instruments Inc. Model ULT-80 Bath Circulator with denatured ethyl alcohol coolant, Model TX-9 ^c Circulator with Dow Corning 710 fluid and necessary hoses and adapters.

^aNot required for Performance Check Procedure.

^bRequires a TM 500-series power module.

^cConnect the TX-9 cooling coil to the cooling pump in the ULT-80 to obtain temperatures between +10°C and +40°C.

WARNING

Dangerous voltages may be encountered in the following steps. Caution must be exercised. Do not contact the output connectors of the voltage calibrator, the INPUT terminals of the DM 502A, or the internal circuitry of the DM 502A. The knob setscrews of some voltage calibrators in the list of test equipment have been known to be at a high voltage potential; check the setscrews with a voltmeter before handling the knobs.

b. Connect the dc voltage calibrator to the VOLTS/Ω and LOW connections through the coaxial cable and bnc female to dual banana adapter.

c. Press the pushbuttons and set the calibrator voltages as listed in Table 4-2.

1. Check Accuracy of Dc Voltage Ranges

a. Set dc voltage calibrator for minimum output voltage.

d. CHECK—that the DM 502A display reads within the given limits for the ambient temperatures as listed in Table 4-2.

Table 4-2
FRONT PANEL DC VOLTAGE LIMITS

Press Pushbuttons VOLTS DC	Dc Calibrator Voltage	Display Limits	
		+18° C to +28° C	0° C to +18° C +28° C to +50° C
200 mV	180.000 mV	179.7 to 180.3	179.5 to 180.5
2 V	1.80000 V	1.797 to 1.803	1.795 to 1.805
20 V	18.0000 V	17.97 to 18.03	17.95 to 18.05
200 V	180.000 V	179.7 to 180.3	179.5 to 180.5
1000 V	1000.000 V	998 to 1002	996 to 1004

e. Set voltage calibrator for minimum output voltage.

h. CHECK—that the display reads ≤ 001.0 .

f. Remove all connections.

i. Turn off the dc voltage from the voltage calibrator.

2. Check Common Mode Rejection (Dc Mode)

a. Connect the bnc female to dual banana connector to the VOLTS/ Ω and LOW connectors.

j. Disconnect the coaxial cable from the dc voltage calibrator and reconnect it to the ac voltage calibrator output.

b. Connect the bnc male to dual binding post connector to the bnc female connector attached to the DM 502A front panel.

k. Set the ac voltage calibrator for an output of 7.07 V rms at a frequency of 50 Hz or 60 Hz, ± 0.2 Hz.

c. Connect the 1 k Ω resistor between the binding posts on the dual binding post connector.

l. CHECK—that the absolute maximum value of the DM 502A display is ≤ 001.0 .

d. Connect the red clip lead of the female bnc to clip lead adapter to the red binding post and the black lead to the ground post on the DM 502A.

NOTE

If the DM 502A does not display the correct reading as stated in step 2 part l, perform step 1 (Clock Adjustment) of the Internal Adjustment Procedure and repeat step 2 parts a through l.

e. Connect the clip lead adapter through a coaxial cable to the dc voltage calibrator.

m. Return voltage calibrator to minimum output.

f. Press the VOLTS DC and 200 mV pushbuttons.

g. Set the dc voltage calibrator for an output of 100 V dc.

n. Remove all connections from the DM 502A front panel except the bnc female to dual banana adapter.

3. Check Normal Mode Rejection (Dc Mode)

- a. Connect the bnc female to dual banana connector to the VOLTS/ Ω and LOW connectors.
- b. Attach the bnc connector through a coaxial cable and adapters to the ac voltage calibrator.
- c. Press the VOLTS DC and 200 mV pushbuttons.
- d. Set the ac calibrator for 0.224 V rms at 50 Hz, ± 0.2 Hz, or 60 Hz, ± 0.2 Hz.
- e. CHECK—that the absolute maximum value of the DM 502A display is ≤ 001.0 .

4. Check Accuracy of Ac Voltage Ranges

- a. Connect the ac voltage calibrator to the VOLTS/ Ω and LOW connections through the coaxial cable and necessary adapters.
- b. Press the pushbuttons and set the ac calibrator voltages as listed in Table 4-3.
- c. CHECK—that the DM 502A display reads within the limits for the ambient temperatures as listed in Table 4-3.
- d. Set the ac voltage calibrator output voltage for minimum output.
- e. Remove all connections.

5. Check Common Mode Rejection (Ac Mode)

- a. Connect the bnc female to dual banana connector to the VOLTS/ Ω and LOW connectors.
- b. Connect the bnc male to dual binding post connector to the bnc female connector attached to the DM 502A front panel.
- c. Connect the 1 k Ω resistor between the binding posts on the dual binding post connector.
- d. Connect the red clip lead of the female bnc to clip lead adapter to the red binding post and the black lead to the ground post on the DM 502A.
- e. Connect the female bnc connector through a coaxial cable and adapters to the ac voltage calibrator.
- f. Press the VOLTS AC and 200 mV pushbuttons.
- g. Set the ac voltage calibrator for an output of 0.707 V ac rms at 60 Hz.
- h. CHECK—that the display reads ≤ 001.0 .
- i. Remove all connections.

**Table 4-3
FRONT PANEL AC VOLTAGE LIMITS**

Press Pushbuttons VOLTS AC TRUE RMS	Calibrator Voltage	Display Limits			
		+18°C to +28°C		0°C to +18°C and +28°C to +50°C	
		40 Hz to 20 kHz	20 Hz to 40 Hz	40 Hz to 20 kHz	20 Hz to 40 Hz
200 mV	180.000 mV	178.3 to 181.7	176.7 to 183.3	177.9 to 182.1	176.1 to 183.9
2 V	1.80000 V	1.783 to 1.817	1.767 to 1.833	1.779 to 1.821	1.761 to 1.839
20 V	18.0000 V	17.83 to 18.17	17.67 to 18.33	17.79 to 18.21	17.61 to 18.39
200 V	180.000 V	178.3 to 181.7	176.7 to 183.3	177.9 to 182.1	176.1 to 183.9
500 V	500.000 V	491 to 509	486 to 514	489 to 511	484 to 516

6. Check Decibel Ranges

a. Connect the ac voltage calibrator to the VOLTS/ Ω and LOW connections through the coaxial cable and necessary adapter.

c. Set calibrator voltage and frequency as listed in Table 4-4.

d. CHECK—that the DM 502A display reads within the tolerances as listed in Table 4-4.

b. Make certain the dBm-dBV internal jumper is in the dBV position.

e. Turn off the ac voltage calibrator and remove all connections.

**Table 4-4
FRONT PANEL dB LIMITS**

Press Pushbuttons VOLTS AC, dB	Calibrator Voltage	Calibrator Frequency	Display Limits	
			+18°C to +28°C	0°C to +18°C +28°C to +50°C
-10	1.00000 mV	20 Hz	-59.5 to -60.5	-58.9 to -61.1
-10	1.00000 mV	2 kHz	-59.5 to -60.5	-58.9 to -61.1
-10	1.00000 mV	20 kHz	-58.5 to -61.5	-57.9 to -62.1
-10	0.100000 V	20 kHz	-19.5 to -20.5	-18.9 to -21.1
+10	1.00000 V	20 Hz	-0.5 to +0.5	-1.1 to +1.1
+30	10.0000 V	20 kHz	+19.5 to +20.5	+18.9 to +21.1
+50	100.000 V	20 kHz	+39.5 to +40.5	+38.9 to +41.1

7. Check Ohms Ranges

a. Connect the resistance standard to the DM 502A VOLTS/ Ω and LOW inputs using the necessary adapter and coaxial cable.

b. Press the k Ω pushbutton. Make each measurement as listed in Table 4-5 with the HI-LO pushbutton in both the HI and LO positions.

c. CHECK—that the display reads within the tolerances as listed in Table 4-5.

d. Remove all connections.

**Table 4-5
FRONT PANEL RESISTANCE LIMITS**

Press Pushbuttons k Ω	Resistance	Display Limits	
		+18°C to +28°C	0°C to +18°C +28°C to +50°C
200 Ω	180.000 Ω	178.8 to 181.2	178.2 to 181.8
2 k Ω	1.80000 k Ω	1.790 to 1.810	1.783 to 1.817
20 k Ω	18.0000 k Ω	17.90 to 18.10	17.84 to 18.16
200 k Ω	180.000 k Ω	179.0 to 181.0	178.4 to 181.6
2000 k Ω	1800.00 k Ω	1790 to 1810	1784 to 1816
20 M Ω	18.0000 M Ω	17.81 to 18.19	17.76 to 18.24

8. Check Dc Current Ranges

- a. Press the mA DC pushbutton.
- b. Set dc current standard for minimum output.
- c. Connect the dc current standard to the DM 502A mA and LOW connections using coaxial cable and necessary adapters.
- d. Set current standard for the values as listed in Table 4-6.
- e. CHECK—that the display reads within the tolerances as listed in Table 4-6.
- f. Remove all connections.

**Table 4-6
FRONT PANEL DC CURRENT LIMITS**

Press Pushbuttons mA DC	Current	Display Limits	
		+18°C to +28°C	0°C to +18°C +28°C to +50°C
200 μ A	180.00 μ A	179.5 to 180.5	179.3 to 180.7
2 mA	1.80000 mA	1.795 to 1.805	1.793 to 1.807
20 mA	18.0000 mA	17.95 to 18.05	17.93 to 18.07
200 mA	180.000 mA	179.5 to 180.5	179.3 to 180.7
2000 mA	1800.00 mA	1795 to 1805	1793 to 1807

9. Check Ac Current Ranges

- a. Press the mA AC pushbutton.
- b. Set ac current standard for minimum output.
- c. Connect the ac current standard to the front panel mA and LOW connections.
- d. Set the ac current standard for the values as listed in Table 4-7. Use any frequency between 40 Hz—20 kHz.
- e. CHECK—that the display reads within the tolerances as listed in Table 4-7.
- f. Remove all connections.

**Table 4-7
FRONT PANEL AC CURRENT LIMITS**

Press Pushbuttons mA AC	Current	Display Limits	
		+18°C to +28°C	0°C to +18°C +28°C to +50°C
200 μ A	180.00 μ A rms	178.3 to 181.7	177.7 to 182.3
2 mA	1.8000 mA	1.783 to 1.817	1.777 to 1.823
20 mA	18.000 mA	17.83 to 18.17	17.77 to 18.23
200 mA	180.00 mA	178.3 to 181.7	177.7 to 182.3
2000 mA	1800.0 mA	1783 to 1817	1777 to 1823

10. Check Temperature Ranges

- a. Connect the temperature probe to the DM 502A front panel connector labeled TEMP.
- b. Press the TEMP°C pushbutton.
- c. Set the bath circulators for the temperatures as listed in the Temperature column in Table 4-8.
- d. Insert the probe in the bath and allow the probe to stabilize at the selected temperature.
- e. CHECK—that the display limits are as listed in Table 4-8.
- f. This completes the front panel performance check.

**Table 4-8
FRONT PANEL TEMPERATURE LIMITS**

P6601 PROBE Temperature	DM 502A Ambient Temperature			
	Probe Calibrated to Instrument		Any probe	
	+18°C to +28°C	0°C to +18°C +28°C to +50°C	+18°C to +28°C	0°C to +18°C +28°C to +50°C
-55°C	-57.5 to -52.5	-59.0 to -51.0	-59.5 to -50.5	-61.0 to -49.0
+150°C	+147.5 to +152.5	+146.0 to +154.0	+145.5 to +154.5	+144.0 to +156.0
+200°C	+196.5 to +203.5	+195.0 to +205.0	+194.5 to +205.5	+193.0 to +207.0

Rear Interface Accuracy Checks

To verify the accuracy of the dc voltage, ac voltage, and resistance modes via the DM 502A rear interface, follow the steps outlined in the Performance Check Procedure for the front panel input jacks, but apply the voltages and resistances to rear interface pins 28B (HIGH) and 28A (LOW). Access to the rear interface pins is most easily made using a TM 500-series, Option 2 power module.

Press the front panel EXT INT pushbutton to select rear interface input and use Table 4-9, Table 4-10, or Table 4-11 for the appropriate display limits.

NOTE

The input cable fixture from the calibrating sources to the rear interface pins will have to be modified to accommodate accuracy checks via the rear interface.

**Table 4-9
REAR INTERFACE DC LIMITS**

Press Pushbuttons VOLTS DC, INT	Calibrator Voltage	Display Limits	
		+18° C to +28° C	0° C to +18° C +28° C to +50° C
200 mV	180.000 mV	179.7 to 180.3	179.5 to 180.5
2 V	1.80000 V	1.797 to 1.803	1.795 to 1.805
20 V	18.0000 V	17.97 to 18.03	17.95 to 18.05
200 V	180.000 V	179.7 to 180.3	179.5 to 180.5
1000 V	200.000 V	199 to 201	199 to 201

Table 4-10
REAR INTERFACE AC LIMITS

Press Pushbuttons VOLTS AC TRUE RMS, INT	Calibrator Voltage rms	Display Limits			
		+18°C to +28°C		0°C to +18°C +28°C to +50°C	
		40 Hz to 20 kHz	20 Hz to 40 Hz	40 Hz to 20 kHz	20 Hz to 40 Hz
200 mV	180.000 mV	177.4 to 182.6	175.8 to 184.2	177.0 to 183.0	175.2 to 184.8
2 V	1.80000 V	1.774 to 1.826	1.758 to 1.842	1.770 to 1.830	1.752 to 1.848
20 V	18.0000 V	17.74 to 18.26	17.58 to 18.42	17.70 to 18.30	17.52 to 18.48
200 V	140.000 V	137.9 to 142.1	136.6 to 143.4	137.5 to 142.5	136.1 to 143.9
500 V	140.000 V	132 to 148	131 to 149	131 to 149	130 to 150

Table 4-11
REAR INTERFACE RESISTANCE LIMITS

Press Pushbuttons INT, kΩ	Resistance	Display Limits	
		+18°C to +28°C	0°C to +18°C +28°C to +50°C
200 Ω	180.000 Ω	178.3 to 181.7	177.7 to 182.3
2 kΩ	1.80000 kΩ	1.789 to 1.811	1.783 to 1.817
20 kΩ	18.0000 kΩ	17.90 to 18.10	17.84 to 18.16
200 kΩ	180.000 kΩ	179.0 to 181.0	178.4 to 181.6
2000 kΩ	1800.00 kΩ	1790 to 1810	1784 to 1816
20 MΩ	18.0000 MΩ	17.81 to 18.19	17.76 to 18.24

ADJUSTMENT PROCEDURE

Introduction

Use this adjustment procedure to restore the DM 502A to original performance requirements. This adjustment procedure need not be performed unless the instrument fails to meet the Performance Requirements of the electrical characteristics listed in the Specification section, or the Performance Check procedure cannot be completed satisfactorily.

Satisfactory completion of all adjustment steps in this procedure ensures that the instrument will meet the Performance Requirements.

Calibration Interval

To ensure instrument accuracy, check the calibration every 1000 hours of operation or at a minimum of every six months if used infrequently.

Services Available

Tektronix, Inc. provides complete instrument repair and adjustment at local field service centers and at the factory service center. Contact your local Tektronix field office or representative for further information.

Test Equipment Required

The test equipment (or equivalent) listed in Table 4-1 is required for adjustment of the DM 502A. Specifications given for the test equipment are the minimum necessary for accurate adjustment. All test equipment is assumed to be correctly calibrated and operating within specifications.

If other test equipment is substituted, calibration setup may need to be altered to meet the requirements of the equipment used.

Preparation

Access to the internal adjustments is achieved most easily when the DM 502A is connected to the power module with a flexible plug-in extender. Access to the adjustments is also easily achieved when the DM 502A is installed in a compartment of a power module with an unused compartment on either side. Remove the power module cabinet to make adjustments to the DM 502A inside the power module. Remove both side covers of the DM 502A. Access adjustments on the analog board through the holes in the shield. See Figs. 8-3 and 8-4 in the foldout pages for adjustment locations. Make adjustments at an ambient temperature between 21°C and 25°C (64°F and 82°F).

Adjustment Instructions

The alphabetical instructions under each step (a, b, c, etc.) may contain CHECK, EXAMINE, or ADJUST as the first word of the instruction. These terms are defined as follows:

1. CHECK—indicates that the instruction accomplishes a performance requirement check. Each performance requirement is derived from the instrument specification as listed in Table 4-1, Electrical Characteristics.

2. EXAMINE—usually precedes an ADJUST instruction and describes how to determine whether the adjustment is necessary. Measurement limits following the word EXAMINE are not to be interpreted as performance limits derived from the instrument specifications. They are provided as indicators of a properly functioning instrument and to aid in the adjustment process.

3. ADJUST—describes which adjustment to use to make the desired result. We recommend that adjustments not be made if a previous CHECK or EXAMINE instruction indicates that no adjustment is necessary.

Perform all steps of the procedure in the order listed.

1. Adjust Clock Frequency

a. Short the VOLTS/ Ω and LOW input connectors with the dual banana plug shorting bar.

b. Connect the counter set to measure 20 kHz through the 1X probe to the clock test point, TP1512, located on the main board.

c. EXAMINE—the counter reading for a frequency of 20.28 kHz to 20.68 kHz.

d. ADJUST—R1523, CLK, located on the main board, for a counter reading of 20.48 kHz.

e. Retain the shorting strap for the next step and remove the counter probe.

2. Adjust the 15 V Power Supply

a. With the input shorted, as in the previous step, connect the digital multimeter probe to TP1542, marked +15 V, as shown in Fig. 8-3 (main board).

b. EXAMINE—the DMM test unit for a reading of +15.74 Vdc to +15.76 Vdc.

c. ADJUST—R1771, +15.75 V, located on the main board, for a DMM test unit reading of +15.75 V.

d. Remove the digital multimeter probe.

3. Adjust DC Volts Zero

a. Make certain the VOLTS/Ω and LOW input connectors are shorted.

b. Press the VOLTS DC pushbutton.

c. Make certain the INPUT pushbutton is in the EXT position (out).

d. Press the 200 mV pushbutton.

e. EXAMINE—the DM 502A display readout for ±000.1.

f. ADJUST—R1542, Dc Volts Zero (located on the main board) for all zeros in the DM 502A display.

g. Remove the shorting connection from the front panel VOLTS/Ω and LOW connectors.

4. Set the 2 V Dc Adjustment

a. Press the VOLTS DC and 2 V pushbuttons. All other pushbuttons out.

b. Connect the dc voltage calibrator, set for an output of 1.9 V, to the front panel VOLTS/Ω and LOW connectors.

c. EXAMINE—the DM 502A display readout for 1.897 Vdc to 1.903 Vdc.

d. ADJUST—R1443, 2 V Dc Adj, located on the main board, for a display readout of 1.900 Vdc.

e. Retain the front-panel connections for the next step.

5. Set the 0.2 V Dc Adjustment

a. Make certain the VOLTS DC and 200 mV pushbuttons are pressed. All other pushbuttons out.

b. Connect the dc voltage calibrator to the front panel VOLTS/Ω and LOW connectors.

c. Set the dc voltage calibrator for an output of 190 mV.

d. EXAMINE—the DM 502A display readout for a reading of 189.7 mVdc to 190.3 mVdc.

e. ADJUST—R1531, 0.2 V Dc Adj, located on the main board, for a display readout of 190.0 mVdc.

f. Remove the dc voltage calibrator from the VOLTS/Ω and LOW connectors.

6. Set the Amp Zero Adjustment

a. Short the VOLTS/Ω and LOW input connectors on the front panel with the shorting bar.

b. Connect the negative lead of the DMM test unit to analog ground or input LOW and the positive lead to TP1013, located on the analog board, (Fig. 8-4).

c. Make certain the VOLTS DC and 200 mV pushbuttons are pressed. All other pushbuttons out.

d. Set the DMM test unit for a resolution of 1 mV.

e. EXAMINE—the DMM test unit for a display reading of 0.000, ±0.001 Vdc.

f. ADJUST—R1011, Amp Zero, located on the analog board, for a DMM test unit display reading of 0.000.

g. Remove the DMM test unit connections.

7. Set the Ac Zero Adjustment

a. Make sure the VOLTS/Ω and LOW connectors are shorted together.

Calibration (Adjustment Procedure)—DM 502A

b. Press the VOLTS AC TRUE RMS pushbutton and make certain the 200 mV pushbutton is pressed. All other pushbuttons out.

c. EXAMINE—the DM 502A display for a reading of 99.8 mVac to 000.2 mVac.

d. ADJUST—R1204, Ac Zero, located on the analog board, for a DM 502A display reading of 000.0.

e. Remove the input shorting bar.

8. Set the Ac Gain Adjustment

a. Make certain the VOLTS AC TRUE RMS and 2 V pushbuttons are pressed. All other pushbuttons out.

b. Set the output of the ac calibrator for 1.9 V rms at a frequency of 100 Hz.

c. Connect the ac calibrator to the VOLTS/ Ω and LOW input connectors.

d. EXAMINE—the DM 502A display for a reading of 1.897 Vac to 1.903 Vac.

e. ADJUST—R1108, Ac Gain, located on the analog board, for a display reading of 1.900 V.

f. Retain this test setup for the next step.

9. Set the Ac Comp Adjustment

a. Make certain the VOLTS AC TRUE RMS and 20 V pushbuttons are pressed. All other pushbuttons out.

b. Connect the ac voltage calibrator to the VOLTS/ Ω and LOW input connectors.

c. Set the output of the ac voltage calibrator for 19 V rms at 10 kHz.

d. EXAMINE—the DM 502A display for a reading of 19.04 V, ± 0.02 V.

e. ADJUST—C1215, Ac Comp, located on the analog board, for a display reading of 19.04 V.

f. Retain these connections for the next step.

10. Set the dB Zero Adjustment

a. Press the VOLTS AC TRUE RMS, dB, and 200 V pushbuttons. All other pushbuttons out.

b. Set the ac voltage calibrator, connected to the front panel VOLTS/ Ω and LOW connectors, for 100 V rms at 100 Hz.

c. Connect the DMM test unit set to read 00.0 mV to TP1108 (Fig. 8-4, analog board).

d. EXAMINE—the DMM test unit display for a reading of 00.0 mV, ± 0.5 mV.

e. ADJUST—R1201, dB Zero, located on the analog board, for a DMM test unit display of 00.0 mV.

f. Retain the front panel connections and remove the DMM test unit probe for the next step.

11. Set the dB Reference Adjustment

a. Make certain the VOLTS AC TRUE RMS, dB, and 200 V pushbuttons are pressed. All other pushbuttons out.

b. Make certain the ac voltage calibrator is connected to the front panel VOLTS/ Ω and LOW input connectors and that the output is set for 100 V rms at 100 Hz.

c. EXAMINE—the DM 502A display for a reading of +39.5 to +40.5.

d. ADJUST—R1518, dB REF, located on the main board, for a DM 502A display reading of +40.0.

e. Set the ac calibrator for minimum output voltage.

f. Retain the front panel connections for the next step.

12. Set the -20 dB Adjustment

a. Make certain the ac voltage calibrator is connected to the front panel VOLTS/ Ω and LOW connectors.

b. Set the ac voltage calibrator for 100 mV rms at a frequency of 100 Hz.

c. Make certain the VOLTS AC TRUE RMS, dB, and 200 mV pushbuttons are pressed. All other pushbuttons out.

d. EXAMINE—the DM 502A display for a reading of -19.5 dB to -20.5 dB.

e. ADJUST—R1521, -20 dB Adj, located on the main board, for a DM 502A display reading of -20.0.

f. Retain the front panel connections for the next step.

13. Set the dB Gain Adjustment

a. Make certain the ac voltage calibrator is connected to the front panel VOLTS/ Ω and LOW connectors.

b. Make certain the VOLTS AC TRUE RMS, dB, and 200 mV pushbuttons are pressed. All other pushbuttons out.

c. Change the output of the ac voltage calibrator to 1 mV rms at 100 Hz.

d. EXAMINE—the DM 502A display for a reading of -59.5 to -60.5.

e. ADJUST—R1102, dB Gain, located on the analog board, for a DM 502A display reading of -60.0.

f. Retain the front panel connections for the next step.

14. Set the dB Overrange Adjustment

a. Make certain the VOLTS AC TRUE RMS, dB, and 2 V pushbuttons are pressed. All other pushbuttons out.

b. Make certain the ac voltage calibrator is connected to the front panel VOLTS/ Ω and LOW connectors.

c. Set the output of the ac voltage calibrator for 4 V rms at 100 Hz.

d. ADJUST—R1024, Or, located on the analog board, so that the DM 502A display just flashes (starts to blink).

e. Set ac calibrator for minimum output voltage.

f. Retain the front panel connections for the next step.

15. Set the dB Underrange Adjustment

a. Make certain the ac voltage calibrator is connected to the front panel VOLTS/ Ω and LOW connectors.

b. Make certain the VOLTS AC TRUE RMS, dB, and 2 V pushbuttons are pressed. All other pushbuttons out.

c. Set the ac voltage calibrator for an output of 0.03 V rms at 100 Hz.

d. ADJUST—R1012, Ur, located on the analog board, so that the display just flashes (starts to blink).

e. Remove the ac voltage calibrator connection from the DM 502A front panel connections.

16. Set the Ohms Adjustment

a. Press the k Ω and 20 k Ω pushbuttons. All other pushbuttons out.

b. Set the resistance standard to 19 k Ω .

c. Connect the resistance standard to the front panel VOLTS/ Ω and LOW connectors.

d. EXAMINE—the DM 502A display for a reading of 18.90 to 19.10.

e. ADJUST—R1306, Ohms, located on the analog board, for a display reading of 19.00.

f. Remove all connections to the DM 502A front panel.

17. Set the Temperature Zero Adjustment

- a. Connect the temperature probe to the front panel TEMP connector.
- b. Place the temperature probe at a known 0.0°C.
- c. Press the TEMP°C pushbutton. All other pushbuttons out.
- d. EXAMINE—the DM 502A display for a reading of 0.0, $\pm 0.2^\circ\text{C}$.
- e. ADJUST—R1001, Temp Zero, for a display reading of 0.0.
- f. Leave the temperature probe connected for the next step.

18. Set the Temperature Gain Adjustment

- a. Make certain the temperature probe is connected to the front panel TEMP connector.
- b. Place the temperature probe tip at a temperature of 100.0°C.
- c. Make certain that the TEMP°C pushbutton is pressed. All other pushbuttons out.
- d. EXAMINE—the DM 502A display for a reading of 101.4.
- e. ADJUST—R1002, Temp, located on the analog board, for a display reading of 101.4.
- f. Remove the temperature probe from the front panel TEMP connector.

This completes the Adjustment Procedure.

MAINTENANCE

Preventive Maintenance

There are no special preventive maintenance procedures that apply to the DM 502A. Refer to the power module instruction manual for general preventive maintenance procedures and instructions.

Corrective Maintenance

Refer to the power module instruction manual for general corrective maintenance procedures and instructions.

Circuit Board Removal

To remove the analog board, first remove both side covers of the instrument. Then remove the main board by unsoldering the connections to the front-panel connectors and removing the four screws holding the main board to the plug-in mainframe. The display board attaches to the main board through a connector and is removed either through the front-panel window or with the main board. To remove the red display screen, press the tabs accessed through the rectangular holes at the top front of the plug-in mainframe.

Slide the boards rearward until the pushbutton switches clear the front-panel. Separate the 31 pin connector by pulling the boards apart. Make certain that the square-pin connectors are not bent during or after disassembly as this causes difficulty during reassembly.

Heat Sink Removal and Replacement

To remove the heat sink from U1651, first unsolder the three leads from the integrated circuit to the circuit board. Then unsolder the two tabs holding the heat sink to the circuit board. Use a screwdriver or other suitable tool to spread the spring tabs holding U1651 in the heat sink. Use care not to spring the tabs beyond their elastic limit. Remove the integrated circuit. Reverse this procedure to install the heat sink.

Obtaining Replacement Parts

Most electrical and mechanical parts can be obtained through your local Tektronix field office or representative. However, you should be able to obtain many of the standard electronic components from a local commercial source in your area. Before you purchase or order a part from a source other than Tektronix Inc., please check the Replaceable Electrical Parts list for the proper value, rating, tolerance, and description.

Ordering Parts

When ordering replacement parts from Tektronix, Inc., it is important that all of the following information be included to ensure receiving the proper parts.

1. Instrument type (include modification or option numbers).
2. Instrument serial number.
3. A description of the part (if electrical, include circuit number).
4. Tektronix part number.

Troubleshooting Aids

Troubleshooting Charts. As an aid in locating problem areas, troubleshooting charts are provided for the DM 502A. They are located in the pullout pages in the rear of this manual.

Static-Sensitive Components



Static discharge can damage any semiconductor component in this instrument.

This instrument contains electrical components that are susceptible to damage from static discharge. See Table 5-1 for relative susceptibility of various classes of semiconductors. Static voltages of 1 kV to 30 kV are common in unprotected environments.

Observe the following precautions to avoid damage:

1. Minimize handling of static-sensitive components.
2. Transport and store static-sensitive components or assemblies in their original containers, on a metal rail, or on conductive foam. Label any package that contains static-sensitive assemblies or components.
3. Discharge the static voltage from your body by wearing a wrist strap while handling these components. Servicing static-sensitive assemblies or components should be performed only at a static-free work station by qualified service personnel.

4. Nothing capable of generating or holding a static charge should be allowed on the work station surface.
5. Keep the component leads shorted together whenever possible.
6. Pick up components by the body, never by the leads.
7. Do not slide the components over any surface.
8. Avoid handling components in areas that have a floor or work surface covering capable of generating a static charge.
9. Use a soldering iron that is connected to earth ground.
10. Use only special antistatic suction type or wick type desoldering tools.

Test Equipment

Before using any test equipment to make measurements on static-sensitive components or assemblies, be certain that any voltage or current supplied by the test equipment does not exceed the limits of the component to be tested.

**Table 5-1
RELATIVE SUSCEPTIBILITY TO
STATIC DISCHARGE DAMAGE**

Semiconductor Classes	Relative Susceptibility Levels ^a
MOS or CMOS microcircuits or discretes, or linear microcircuits with MOS inputs. (Most Sensitive)	1
ECL	2
Schottky signal diodes	3
Schottky TTL	4
High-frequency bipolar transistors	5
JFETs	6
Linear microcircuits	7
Low-power Schottky TTL	8
TTL (Least Sensitive)	9

^aVoltage equivalent for levels:

1 = 100 to 500 V	4 = 500 V	7 = 400 to 1000 V (est.)
2 = 200 to 500 V	5 = 400 to 600 V	8 = 900 V
3 = 250 V	6 = 600 to 800 V	9 = 1200 V

(Voltage discharged from a 100 pF capacitor through a resistance of 100 ohms.)

OPTIONS

The standard instrument incorporates the temperature measuring capability using a TEKTRONIX P6601 probe or other suitable sensing device.

An Option 2 instrument deletes the temperature measurement function, P6601 temperature probe, and all internal circuits associated with this function.

Information concerning an Option 2 instrument can be found on schematic diagram , in the Replaceable Electrical Parts list, and in the Calibration section of this manual. Information concerning the TEKTRONIX P6601 Temperature Probe can be found in the instruction manual for that accessory.

REPLACEABLE ELECTRICAL PARTS

PARTS ORDERING INFORMATION

Replacement parts are available from or through your local Tektronix, Inc. Field Office or representative.

Changes to Tektronix instruments are sometimes made to accommodate improved components as they become available, and to give you the benefit of the latest circuit improvements developed in our engineering department. It is therefore important, when ordering parts, to include the following information in your order: Part number, instrument type or number, serial number, and modification number if applicable.

If a part you have ordered has been replaced with a new or improved part, your local Tektronix, Inc. Field Office or representative will contact you concerning any change in part number.

Change information, if any, is located at the rear of this manual.

Only the circuit number will appear on the diagrams and circuit board illustrations. Each diagram and circuit board illustration is clearly marked with the assembly number. Assembly numbers are also marked on the mechanical exploded views located in the Mechanical Parts List. The component number is obtained by adding the assembly number prefix to the circuit number.

The Electrical Parts List is divided and arranged by assemblies in numerical sequence (e.g., assembly A1 with its subassemblies and parts, precedes assembly A2 with its subassemblies and parts).

Chassis-mounted parts have no assembly number prefix and are located at the end of the Electrical Parts List.

LIST OF ASSEMBLIES

A list of assemblies can be found at the beginning of the Electrical Parts List. The assemblies are listed in numerical order. When the complete component number of a part is known, this list will identify the assembly in which the part is located.

TEKTRONIX PART NO. (column two of the Electrical Parts List)

Indicates part number to be used when ordering replacement part from Tektronix.

CROSS INDEX-MFR. CODE NUMBER TO MANUFACTURER

The Mfr. Code Number to Manufacturer index for the Electrical Parts List is located immediately after this page. The Cross Index provides codes, names and addresses of manufacturers of components listed in the Electrical Parts List.

SERIAL/MODEL NO. (columns three and four of the Electrical Parts List)

Column three (3) indicates the serial number at which the part was first used. Column four (4) indicates the serial number at which the part was removed. No serial number entered indicates part is good for all serial numbers.

ABBREVIATIONS

Abbreviations conform to American National Standard Y1.1.

NAME & DESCRIPTION (column five of the Electrical Parts List)

In the Parts List, an Item Name is separated from the description by a colon (:). Because of space limitations, an Item Name may sometimes appear as incomplete. For further Item Name identification, the U.S. Federal Cataloging Handbook H6-1 can be utilized where possible.

COMPONENT NUMBER (column one of the Electrical Parts List)

A numbering method has been used to identify assemblies, subassemblies and parts. Examples of this numbering method and typical expansions are illustrated by the following:

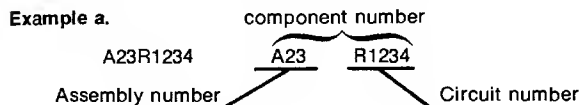

Read: Resistor 1234 of Assembly 23

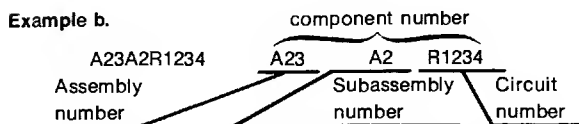

Read: Resistor 1234 of Subassembly 2 of Assembly 23

MFR. CODE (column six of the Electrical Parts List)

Indicates the code number of the actual manufacturer of the part. (Code to name and address cross reference can be found immediately after this page.)

MFR. PART NUMBER (column seven of the Electrical Parts List)

Indicates actual manufacturers part number.

CROSS INDEX—MFR. CODE NUMBER TO MANUFACTURER

Mfr. Code	Manufacturer	Address	City, State, Zip
00853	SANGAMO ELECTRIC CO., S. CAROLINA DIV.	P O BOX 128	PICKENS, SC 29671
01121	ALLEN-BRADLEY COMPANY	1201 2ND STREET SOUTH	MILWAUKEE, WI 53204
01295	TEXAS INSTRUMENTS, INC., SEMICONDUCTOR GROUP	P O BOX 5012, 13500 N CENTRAL EXPRESSWAY	DALLAS, TX 75222
04713	MOTOROLA, INC., SEMICONDUCTOR PROD. DIV.	5005 E MCDOWELL RD, PO BOX 20923	PHOENIX, AZ 85036
07263	FAIRCHILD SEMICONDUCTOR, A DIV. OF FAIRCHILD CAMERA AND INSTRUMENT CORP.	464 ELLIS STREET	MOUNTAIN VIEW, CA 94042
07716	TRW ELECTRONIC COMPONENTS, IRC FIXED RESISTORS, BURLINGTON DIV.	2850 MT. PLEASANT GROVE & LAKE STS.	BURLINGTON, IA 52601
12617	HAMLIN, INC.	3301 ELECTRONICS WAY	LAKE MILLS, WI 53551
14433	ITT SEMICONDUCTORS	P O BOX 3049	WEST PALM BEACH, FL 33402
14752	ELECTRO CUBE INC.	1710 S. DEL MAR AVE.	SAN GABRIEL, CA 91776
17856	SILICONIX, INC.	2201 LAURELWOOD DRIVE	SANTA CLARA, CA 95054
19396	ILLINOIS TOOL WORKS, INC. PAKTRON DIV.	900 FOLLIN LANE, SE	VIENNA, VA 22180
19647	CADDOCK ELECTRONICS INC.	3127 CHICAGO AVENUE	RIVERSIDE, CA 92507
21317	ELECTRONIC APPLICATIONS COMPANY	2213 EDWARDS AVENUE	SOUTH EL MONTE, CA 91733
24546	CORNING GLASS WORKS, ELECTRONIC COMPONENTS DIVISION	550 HIGH STREET	BRADFORD, PA 16701
27014	NATIONAL SEMICONDUCTOR CORP.	2900 SEMICONDUCTOR DR.	SANTA CLARA, CA 95051
50157	MIDWEST COMPONENTS INC.	P. O. BOX 787	
50522	MONSANTO CO., ELECTRONIC SPECIAL PRODUCTS	1981 PORT CITY BLVD.	MUSKEGON, MI 49443
54473	MATSUSHITA ELECTRIC, CORP. OF AMERICA	3400 HILLVIEW AVENUE	PALO ALTO, CA 94304
55680	NICHICON/AMERICA/CORP.	1 PANASONIC WAY	SECAUCUS, NJ 07094
56289	SPRAGUE ELECTRIC CO.	6435 N PROESEL AVENUE	CHICAGO, IL 60645
71400	BUSSMAN MFG., DIVISION OF MCGRAW-EDISON CO.		NORTH ADAMS, MA 01247
71590	CENTRALAB ELECTRONICS, DIV. OF GLOBE-UNION, INC.	2536 W. UNIVERSITY ST.	ST. LOUIS, MO 63107
71744	CHICAGO MINIATURE LAMP WORKS	P O BOX 858	FORT DODGE, IA 50501
72136	ELECTRO MOTIVE CORPORATION, SUB OF INTERNATIONAL ELECTRONICS CORPORATION	4433 RAVENSWOOD AVE.	CHICAGO, IL 60640
72982	ERIE TECHNOLOGICAL PRODUCTS, INC.	LAUTER AVE, P O BOX 7600	FLORENCE, SC 29501
73138	BECKMAN INSTRUMENTS, INC., HELIPOT DIV.	644 W. 12TH ST.	ERIE, PA 16512
80009	TEKTRONIX, INC.	2500 HARBOR BLVD.	FULLERTON, CA 92634
90201	MALLORY CAPACITOR CO., DIV. OF P. R. MALLORY AND CO., INC.	P O BOX 500	BEAVERTON, OR 97077
91418	RADIO MATERIALS COMPANY, DIV. OF P.R. MALLORY AND COMPANY, INC.	3029 E. WASHINGTON STREET	INDIANAPOLIS, IN 46206
91637	DALE ELECTRONICS, INC.	P. O. BOX 372	
		4242 W BRYN MAWR	CHICAGO, IL 60646
		P. O. BOX 609	COLUMBUS, NE 68601

Component No.	Tektronix Part No.	Serial/Model No. Eff Dscont	Name & Description	Mfr Code	Mfr Part Number
A11	670-6010-00		CKT BOARD ASSY:DISPLAY	80009	670-6010-00
A13	670-6009-00		CKT BOARD ASSY:ANALOG	80009	670-6009-00
	-----		(STANDARD ONLY)		
A13	670-6018-00		CKT BOARD ASSY:ANALOG	80009	670-6018-00
	-----		(OPTION 2 ONLY)		
A15	670-6008-00		CKT BOARD ASSY:MAIN	80009	670-6008-00
A11	-----		CKT BOARD ASSY:DISPLAY		
A11DS1101	150-1036-00		LAMP,LED:RED,3.0V,40MA	01295	TIL 209A
A11DS1102	150-1036-00		LAMP,LED:RED,3.0V,40MA	01295	TIL 209A
A11R1001	315-0271-00		RES.,FXD,CMPSN:270 OHM,5%,0.25W	01121	CB2715
A11U1001	150-1066-00		LAMP,LED RDOUT:ORANGE,6 SEG,+/-1	50522	MAN 4605
A13	-----		CKT BOARD ASSY:ANALOG		
A13C1117	290-0290-00		CAP.,FXD,ELCTLT:10UF,20%,25V	56289	30D472
A13C1202	290-0488-00		CAP.,FXD,ELCTLT:2.2UF,10%,20V	90201	TAC225K020P02
A13C1203	281-0775-00		CAP.,FXD,CER DI:0.1UF,20%,50V	72982	8005D9AABZ5U104M
A13C1204	281-0773-00		CAP.,FXD,CER DI:0.01UF,10%,100V	72982	8005H9AADW5R103K
A13C1206	281-0773-00		CAP.,FXD,CER DI:0.01UF,10%,100V	72982	8005H9AADW5R103K
A13C1208	281-0773-00		CAP.,FXD,CER DI:0.01UF,10%,100V	72982	8005H9AADW5R103K
A13C1212	283-0793-00		CAP.,FXD,MICA D:3035PF,1%,500V	72136	DM19FD30350FO
A13C1213	283-0431-00		CAP.,FXD,CER DI:28PF,1%,1000V	91418	CN028DF1021RO
A13C1215	281-0064-00		CAP.,VAR,PLSTC:0.25-1.5PF,600V	72982	530-002
A13C1302	281-0773-00		CAP.,FXD,CER DI:0.01UF,10%,100V	72982	8005H9AADW5R103K
A13C1308	285-1101-00		CAP.,FXD,PLSTC:0.022UF,10%,200V	19396	223K02PT485
A13C1401	285-1077-00		CAP.,FXD,PLSTC:0.10UF,20%,600V	14752	230B1F104
A13CR1019	153-0057-00		SEMICON DVC,SE:SILICON,40 PIV,200MA,SEL	80009	153-0057-00
A13CR1021	152-0141-02		SEMICON DVC:SEMICON,30V,50NA	01295	1N4152R
A13CR1027	152-0141-02		SEMICON DVC:SEMICON,30V,50NA	01295	1N4152R
A13CR1101	152-0141-02		SEMICON DVC:SEMICON,30V,50NA	01295	1N4152R
	-----		(STANDARD ONLY)		
A13CR1111	153-0057-00		SEMICON DVC,SE:SILICON,40 PIV,200MA,SEL	80009	153-0057-00
A13CR1115	152-0141-02		SEMICON DVC:SEMICON,30V,50NA	01295	1N4152R
A13CR1121	152-0149-00	XB010210	SEMICON DVC:ZENER,0.4W,10V,5%	80009	152-0149-00
	-----		(STANDARD ONLY)		
A13CR1121	152-0149-00	XB010255	SEMICON DVC:ZENER,0.4W,10V,5%	80009	152-0149-00
	-----		(OPTION 2 ONLY)		
A13CR1122	152-0149-00	XB010210	SEMICON DVC:ZENER,0.4W,10V,5%	80009	152-0149-00
	-----		(STANDARD ONLY)		
A13CR1122	152-0149-00	XB010255	SEMICON DVC:ZENER,0.4W,10V,5%	80009	152-0149-00
	-----		(OPTION 2 ONLY)		
A13CR1121	152-0149-00		SEMICON DVC:ZENER,0.4W,10V,5%	80009	152-0149-00
A13CR1122	152-0149-00		SEMICON DVC:ZENER,0.4W,10V,5%	80009	152-0149-00
A13CR1217	152-0141-02		SEMICON DVC:SEMICON,30V,50NA	01295	1N4152R
A13CR1408	152-0141-02		SEMICON DVC:SEMICON,30V,50NA	01295	1N4152R
A13DS1014	150-0131-00		LAMP,INCAND:120V,0.025A	71744	120PS
A13K1113	148-0126-00		RELAY,REED:400 OHM COIL,500MA,250V	21317	BEE-5
A13K1114	148-0126-00		RELAY,REED:400 OHM COIL,500MA,250V	21317	BEE-5
A13K1115	148-0126-00		RELAY,REED:400 OHM COIL,500MA,250V	21317	BEE-5
A13K1216	108-0966-00		COIL,RF:FIXED,REED SWITCH,4V,SINGLE	80009	108-0966-00
A13Q1214	151-0188-00		TRANSISTOR:SEMICON,PNP	80009	151-0188-00
A13Q1301	151-0232-00		TRANSISTOR:SEMICON,NPN,DUAL	80009	151-0232-00
A13Q1309	151-0188-00		TRANSISTOR:SEMICON,PNP	80009	151-0188-00
A13Q1312	151-0190-00		TRANSISTOR:SEMICON,NPN	07263	S032677
A13R1001	311-1560-00		RES.,VAR,NONWIR:5K OHM,20%,0.50W	73138	91A R5K
	-----		(STANDARD ONLY)		

Replaceable Electrical Parts—DM 502A

Component No.	Tektronix Part No.	Serial/Model No. Eff Dscont	Name & Description	Mfr Code	Mfr Part Number
A13R1002	311-1558-00		RES.,VAR, NONWIR:20K OHM,20%,0.50W (STANDARD ONLY)	73138	91-80-0
A13R1003	321-0331-09		RES.,FXD,FILM:27.4K OHM,1%,0.125W (STANDARD ONLY)	91637	MFF1816C27401F
A13R1005	321-1653-04		RES.,FXD,FILM:2.25M OHM,0.1%,0.125W (STANDARD ONLY)	91637	HMF188D22503B
A13R1006	321-0443-00		RES.,FXD,FILM:402K OHM,1%,0.125W (STANDARD ONLY)	91637	MFF1816G40202F
A13R1011	311-1559-00		RES.,VAR, NONWIR:10K OHM,20%,0.50W	73138	91A-10001M
A13R1012	311-1555-00		RES.,VAR, NONWIR:100K OHM,20%,0.5W	73138	91-77-0
A13R1013	321-0816-00		RES.,FXD,FILM:5K OHM,1%,0.125W	24546	NA55D5000F
A13R1014	315-0620-00		RES.,FXD,CMPSN:62 OHM,5%,0.25W	01121	CB6205
A13R1015	321-0481-00		RES.,FXD,FILM:1M OHM,1%,0.125W	91637	MFF1816G10003F
A13R1016	321-0289-00		RES.,FXD,FILM:10K OHM,1%,0.125W	91637	MFF1816G10001F
A13R1017	321-0289-00		RES.,FXD,FILM:10K OHM,1%,0.125W	91637	MFF1816G10001F
A13R1018	321-0995-00		RES.,FXD,FILM:549K OHM,1%,0.125W	24546	NA55D5493F
A13R1019	321-0306-09		RES.,FXD,FILM:15K OHM,1%,0.125W (STANDARD ONLY)	24546	NE55E1502F
A13R1022	315-0104-00		RES.,FXD,CMPSN:100K OHM,5%,0.25W	01121	CB1045
A13R1023	315-0620-00		RES.,FXD,CMPSN:62 OHM,5%,0.25W	01121	CB6205
A13R1024	311-1555-00		RES.,VAR, NONWIR:100K OHM,20%,0.5W	73138	91-77-0
A13R1026	321-0816-00		RES.,FXD,FILM:5K OHM,1%,0.125W	24546	NA55D5000F
A13R1028	315-0104-00		RES.,FXD,CMPSN:100K OHM,5%,0.25W	01121	CB1045
A13R1101	321-0199-00		RES.,FXD,FILM:1.15K OHM,1%,0.125W (STANDARD ONLY)	91637	MFF1816G11500F
A13R1102	311-1565-00		RES.,VAR, NONWIR:250 OHM,20%,0.50W	73138	91A R250
A13R1103	321-0356-00		RES.,FXD,FILM:49.9K OHM,1%,0.125W (STANDARD ONLY)	91637	MFF1816G49901F
A13R1103	-----				
A13R1105	321-0247-00		RES.,FXD,FILM:3.65K OHM,1%,0.125W	91637	MFF1816G36500F
A13R1107	308-0817-00		RES.,FXD,WW:1K OHM,5%,0.125W	91637	RS1A-144
A13R1108	311-1566-00		RES.,VAR, NONWIR:200 OHM,20%,0.50W	73138	91-88-0
A13R1112	315-0203-00		RES.,FXD,CMPSN:20K OHM,5%,0.25W	01121	CB2035
A13R1113	321-1718-07		RES.,FXD,FILM:1.111K OHM,0.1%,0.125W	91637	CMF1/10-216-C111
A13R1114	321-0289-07		RES.,FXD,FILM:10K OHM,0.1%,0.125W	91637	MFF1816C10001B
A13R1116	321-0126-00		RES.,FXD,FILM:200 OHM,1%,0.125W	91637	MFF1816G200R0F
A13R1118A-C	307-0644-00		RES,NTWK,FXD FI:1,9.9M OHM,1,9K,1,10K OHM	19647	1776-81
A13R1121	315-0471-00	B010100 B010209X	RES.,FXD,CMPSN:470 OHM,5%,0.25W (STANDARD ONLY)	01121	CB4715
A13R1121	315-0471-00	B010100 B010254X	RES.,FXD,CMPSN:470 OHM,5%,0.25W (OPTION 2 ONLY)	01121	CB4715
A13R1122	315-0471-00	B010100 B010209X	RES.,FXD,CMPSN:470 OHM,5%,0.25W (STANDARD ONLY)	01121	CB4715
A13R1122	315-0471-00	B010100 B010254X	RES.,FXD,CMPSN:470 OHM,5%,0.25W (OPTION 2 ONLY)	01121	CB4715
A13R1201	311-1550-00		RES.,VAR, NONWIR:2M OHM,20%,0.50W	73138	91-72-0
A12R1202	321-0452-00		RES.,FXD,FILM:499K OHM,1%,0.125W	91637	MFF1816G49902F
A13R1204	311-1555-00		RES.,VAR, NONWIR:100K OHM,20%,0.5W	73138	91-77-0
A13R1205	321-0381-00		RES.,FXD,FILM:90.9K OHM,1%,0.125W	91637	MFF1816G90901F
A13R1207	321-0107-00		RES.,FXD,FILM:127 OHM,1%,0.125W	91637	MFF1816G127R0F
A13R1211	321-0222-00		RES.,FXD,FILM:2K OHM,1%,0.125W	91637	MFF1816G20000F
A13R1218	307-0643-00		RES.,FXD,FILM:200K OHM,1.0%,3W	91637	F69-20002F
A13R1219	307-0645-00		RES.,THERMAL:5K OHM,40%	50157	180050212
A13R1221	315-0203-00		RES.,FXD,CMPSN:20K OHM,5%,0.25W	01121	CB2035
A13R1304	321-0188-00		RES.,FXD,FILM:887 OHM,1%,0.125W	91637	MFF1816G887R0F
A13R1305	315-0512-00		RES.,FXD,CMPSN:5.1K OHM,5%,0.25W	01121	CB5125
A13R1306	311-1563-00		RES.,VAR, NONWIR:1K OHM,20%,0.50W	73138	91A R1K
A13R1307	321-1617-06		RES.,FXD,FILM:5.85K OHM,0.25%,0.125W	91637	MFF1816C58500C

Component No.	Tektronix Part No.	Serial/Model No. Eff Dscont	Name & Description	Mfr Code	Mfr Part Number
A13R1314	315-0203-00		RES., FXD, CMPSN: 20K OHM, 5%, 0.25W	01121	CB2035
A13R1315	315-0103-00		RES., FXD, CMPSN: 10K OHM, 5%, 0.25W	01121	CB1035
A13R1316	315-0202-00		RES., FXD, CMPSN: 2K OHM, 5%, 0.25W	01121	CB2025
A13R1317	315-0103-00		RES., FXD, CMPSN: 10K OHM, 5%, 0.25W	01121	CB1035
A13R1318	315-0202-00		RES., FXD, CMPSN: 2K OHM, 5%, 0.25W	01121	CB2025
A13R1319	315-0103-00		RES., FXD, CMPSN: 10K OHM, 5%, 0.25W	01121	CB1035
A13R1402	315-0102-00		RES., FXD, CMPSN: 1K OHM, 5%, 0.25W	01121	CB1025
A13R1411	315-0103-00		RES., FXD, CMPSN: 10K OHM, 5%, 0.25W	01121	CB1035
A13R1412	315-0103-00		RES., FXD, CMPSN: 10K OHM, 5%, 0.25W	01121	CB1035
A13R1413	315-0103-00		RES., FXD, CMPSN: 10K OHM, 5%, 0.25W	01121	CB1035
A13R1414	315-0103-00		RES., FXD, CMPSN: 10K OHM, 5%, 0.25W	01121	CB1035
A13R1416	321-0481-07		RES., FXD, FILM: 1M OHM, 0.1%, 0.125W	91637	HFF188C10003B
A13S1A-F	260-1949-00		SWITCH, PUSH: 6 BTN, 0/2/4/6 POLE, FUNCTION (STANDARD ONLY)	71590	2KBC1130001230
A13S1A-E	260-1948-00		SWITCH, PUSH: 5 BTN, 0/2/4 POLE, FUNCTION (OPTION 2 ONLY)	80009	260-1948-00
A13SA, B	260-1950-00		SWITCH, PUSH: 2 BTN, LOW HIGH DB	71590	2KBB0110001231
A13S4	260-1952-00		SWITCH, PUSH: 1 BTN, INPUT	71590	2KAB0100001095
A13S1216	260-0722-00		SWITCH, REED: 0.5A, 500V, 10W	12617	MRR-5
A13U1004	156-0158-00		MICROCIRCUIT, LI: DUAL OPERATIONAL AMPLIFIER	80009	156-0158-00
A13U1013	156-1134-00		MICROCIRCUIT, LI: OPERATIONAL AMPLIFIER	80009	156-1134-00
A13U1015	156-0067-00		MICROCIRCUIT, LI: OPERATIONAL AMPLIFIER	80009	156-0067-00
A13U1025	156-0158-00		MICROCIRCUIT, LI: DUAL OPERATIONAL AMPLIFIER	80009	156-0158-00
A13U1205	156-1259-00		MICROCIRCUIT, LI: RMS/DC CONVERTER	80009	156-1259-00
A13VR1303	152-0317-00		SEMICONV DEVICE: ZENER, 0.25W, 6.2V, 5%	80009	152-0317-00
A15	-----		CKT BOARD ASSY: MAIN		
A15C1144	281-0775-00		CAP., FXD, CER DI: 0.1UF, 20%, 50V	72982	8005D9AABZ5U104M
A15C1211	290-0748-00		CAP., FXD, ELCTLT: 10UF, +50-10%, 20V	56289	500D149
A15C1316	281-0773-00		CAP., FXD, CER DI: 0.01UF, 10%, 100V	72982	8005H9AADW5R103K
A15C1318	281-0773-00		CAP., FXD, CER DI: 0.01UF, 10%, 100V	72982	8005H9AADW5R103K
A15C1331	290-0748-00		CAP., FXD, ELCTLT: 10UF, +50-10%, 20V	56289	500D149
A15C1432	285-1101-00		CAP., FXD, PLSTC: 0.022UF, 10%, 200V	19396	223K02PT485
A15C1461	281-0775-00		CAP., FXD, CER DI: 0.1UF, 20%, 50V	72982	8005D9AABZ5U104M
A15C1553	281-0763-00		CAP., FXD, CER DI: 47PF, 10%, 100V	72982	8035D9AADC1G470K
A15C1561	285-0919-00		CAP., FXD, PLSTC: 0.22UF, 10%, 100V	56289	LP66A1B224K002
A15C1562	285-1102-00		CAP., FXD, PLSTC: 0.1UF, 20%, 100V	19396	PT720B104M
A15C1563	290-0415-00		CAP., FXD, ELCTLT: 5.6UF, 10%, 35V	56289	150D565X9035B2
A15C1564	290-0415-00		CAP., FXD, ELCTLT: 5.6UF, 10%, 35V	56289	150D565X9035B2
A15C1567	281-0775-00		CAP., FXD, CER DI: 0.1UF, 20%, 50V	72982	8005D9AABZ5U104M
A15C1601	283-0693-00		CAP., FXD, MICA D: 1730PF, 1%, 300V	00853	D19-5F1731F0
A15C1612	281-0773-00		CAP., FXD, CER DI: 0.01UF, 10%, 100V	72982	8005H9AADW5R103K
A15C1624	290-0134-00		CAP., FXD, ELCTLT: 22UF, 20%, 15V	56289	150D226X0015B2
A15C1641	290-0844-00		CAP., FXD, ELCTLT: 100UF, -10+75%, 35 WVDC	54473	ECE-A35V100L
A15C1661	290-0845-00		CAP., FXD, ELCTLT: 330UF, 10+50%, 25 WVDC	55680	25ULA330
A15C1742	290-0846-00		CAP., FXD, ELCTLT: 47UF, -10+75%, 35 WVDC	54473	ECE-A35V47LU
A15C1751	281-0775-00		CAP., FXD, CER DI: 0.1UF, 20%, 50V	72982	8005D9AABZ5U104M
A15C1761	290-0267-00		CAP., FXD, ELCTLT: 1UF, 20%, 35V	56289	162D105X0035CD2
A15CR1134	152-0075-00		SEMICONV DEVICE: GE, 25V, 40MA	14433	G866
A15CR1136	152-0075-00		SEMICONV DEVICE: GE, 25V, 40MA	14433	G866
A15CR1152	152-0488-00		SEMICONV DEVICE: SILICON, 200V, 1500MA	80009	152-0488-00
A15CR1251	152-0075-00		SEMICONV DEVICE: GE, 25V, 40MA	14433	G866
A15CR1261	152-0075-00		SEMICONV DEVICE: GE, 25V, 40MA	14433	G866
A15CR1651	152-0066-00		SEMICONV DEVICE: SILICON, 400V, 750MA	14433	LG4016
A15CR1652	152-0066-00		SEMICONV DEVICE: SILICON, 400V, 750MA	14433	LG4016

Replaceable Electrical Parts—DM 502A

Component No.	Tektronix Part No.	Serial/Model No. Eff Dscont	Name & Description	Mfr Code	Mfr Part Number
A15CR1741	152-0585-00		SEMICONV DEVICE: SILICON, BRIDGE, 200V, 1A	80009	152-0585-00
A15F1071	159-0021-00		FUSE, CARTRIDGE: 3AG, 2A, 250V, FAST-BLOW	71400	AGC 2
A15K1442	148-0126-00		RELAY, REED: 400 OHM COIL, 500MA, 250V	21317	BEE-5
A15Q1028	151-0301-00		TRANSISTOR: SILICON, PNP	04713	2N2907A
A15Q1105	151-0301-00		TRANSISTOR: SILICON, PNP	04713	2N2907A
A15Q1121	151-0301-00		TRANSISTOR: SILICON, PNP	04713	2N2907A
A15Q1124	151-0301-00		TRANSISTOR: SILICON, PNP	04713	2N2907A
A15Q1126	151-0301-00		TRANSISTOR: SILICON, PNP	04713	2N2907A
A15Q1456	151-0188-00		TRANSISTOR: SILICON, PNP	80009	151-0188-00
A15Q1472	151-1068-00		TRANSISTOR: SILICON, JFE, SEL FROM 2N4340	80009	151-1068-00
A15Q1533	151-0190-00		TRANSISTOR: SILICON, NPN	07263	S032677
A15R1001	315-0221-00		RES., FXD, CMPSN: 220 OHM, 5%, 0.25W	01121	CB2215
A15R1002	315-0221-00		RES., FXD, CMPSN: 220 OHM, 5%, 0.25W	01121	CB2215
A15R1003	315-0221-00		RES., FXD, CMPSN: 220 OHM, 5%, 0.25W	01121	CB2215
A15R1012	315-0301-00		RES., FXD, CMPSN: 300 OHM, 5%, 0.25W	01121	CB3015
A15R1013	315-0221-00		RES., FXD, CMPSN: 220 OHM, 5%, 0.25W	01121	CB2215
A15R1014	315-0152-00		RES., FXD, CMPSN: 1.5K OHM, 5%, 0.25W	01121	CB1525
A15R1031	315-0560-00		RES., FXD, CMPSN: 56 OHM, 5%, 0.25W	01121	CB5605
A15R1038	315-0221-00		RES., FXD, CMPSN: 220 OHM, 5%, 0.25W	01121	CB2215
A15R1041A, B, C	307-0400-00		RES., FXD, FILM: 10 OHM, 0.1%	80009	307-0400-00
A15R1058	321-0895-07		RES., FXD, FILM: 90 OHM, 0.1%, 0.125W	91637	MFF1816C90R00B
A15R1102	315-0221-00		RES., FXD, CMPSN: 220 OHM, 5%, 0.25W	01121	CB2215
A15R1103	315-0221-00		RES., FXD, CMPSN: 220 OHM, 5%, 0.25W	01121	CB2215
A15R1104	315-0221-00		RES., FXD, CMPSN: 220 OHM, 5%, 0.25W	01121	CB2215
A15R1107	315-0223-00		RES., FXD, CMPSN: 22K OHM, 5%, 0.25W	01121	CB2235
A15R1109	315-0821-00		RES., FXD, CMPSN: 820 OHM, 5%, 0.25W	01121	CB8215
A15R1111	315-0511-00		RES., FXD, CMPSN: 510 OHM, 5%, 0.25W	01121	CB5115
A15R1112	315-0152-00		RES., FXD, CMPSN: 1.5K OHM, 5%, 0.25W	01121	CB1525
A15R1113	315-0511-00		RES., FXD, CMPSN: 510 OHM, 5%, 0.25W	01121	CB5115
A15R1114	315-0152-00		RES., FXD, CMPSN: 1.5K OHM, 5%, 0.25W	01121	CB1525
A15R1115	315-0511-00		RES., FXD, CMPSN: 510 OHM, 5%, 0.25W	01121	CB5115
A15R1116	315-0152-00		RES., FXD, CMPSN: 1.5K OHM, 5%, 0.25W	01121	CB1525
A15R1117	315-0103-00		RES., FXD, CMPSN: 10K OHM, 5%, 0.25W	01121	CB1035
A15R1118	315-0511-00		RES., FXD, CMPSN: 510 OHM, 5%, 0.25W	01121	CB5115
A15R1119	315-0221-00		RES., FXD, CMPSN: 220 OHM, 5%, 0.25W	01121	CB2215
A15R1132	315-0221-00		RES., FXD, CMPSN: 220 OHM, 5%, 0.25W	01121	CB2215
A15R1137	315-0821-00		RES., FXD, CMPSN: 820 OHM, 5%, 0.25W	01121	CB8215
A15R1151	321-0754-07		RES., FXD, FILM: 900 OHM, 0.1%, 0.125W	91637	MFF1816C900R0B
A15R1311	315-0512-00		RES., FXD, CMPSN: 5.1K OHM, 5%, 0.25W	01121	CB5125
A15R1325	315-0391-00		RES., FXD, CMPSN: 390 OHM, 5%, 0.25W	01121	CB3915
A15R1358	315-0103-00		RES., FXD, CMPSN: 10K OHM, 5%, 0.25W	01121	CB1035
A15R1378	307-0110-00		RES., FXD, CMPSN: 3 OHM, 5%, 0.25W	01121	CB30G5
A15R1404	315-0512-00		RES., FXD, CMPSN: 5.1K OHM, 5%, 0.25W	01121	CB5125
A15R1416	321-1625-06		RES., FXD, FILM: 277.8K OHM, 0.25%, 0.125W	91637	MFF1816C27780C
A15R1418	321-0266-00		RES., FXD, FILM: 5.76K OHM, 1%, 0.125W	91637	MFF1816G57600F
A15R1441	321-1643-07		RES., FXD, FILM: 11.03K OHM, 0.1%, 0.125W	91637	MFF1816C11031B
A15R1443	311-1559-00		RES., VAR, NONWIR: 10K OHM, 20%, 0.50W	73138	91A-10001M
A15R1452	315-0224-00		RES., FXD, CMPSN: 220K OHM, 5%, 0.25W	01121	CB2245
A15R1453	315-0164-00		RES., FXD, CMPSN: 160K OHM, 5%, 0.25W	01121	CB1645
A15R1454	315-0333-00		RES., FXD, CMPSN: 33K OHM, 5%, 0.25W	01121	CB3335
A15R1455	315-0333-00		RES., FXD, CMPSN: 33K OHM, 5%, 0.25W	01121	CB3335
A15R1457	321-0385-07		RES., FXD, FILM: 100K OHM, 0.1%, 0.125W	91637	MFF1816C10002B
A15R1458	321-1691-07		RES., FXD, FILM: 74.44K OHM, 0.1%, 0.125W	07716	CEAE74441B
A15R1462	315-0105-00		RES., FXD, CMPSN: 1M OHM, 5%, 0.25W	01121	CB1055
A15R1464	315-0104-00		RES., FXD, CMPSN: 100K OHM, 5%, 0.25W	01121	CB1045
A15R1466	321-1719-07		RES., FXD, FILM: 112.5K OHM, 0.10%, 0.125W	24546	NE55E11252B
A15R1502	315-0103-00		RES., FXD, CMPSN: 10K OHM, 5%, 0.25W	01121	CB1035

Component No.	Tektronix Part No.	Serial/Model No. Eff Dscont	Name & Description	Mfr Code	Mfr Part Number
A15R1503	315-0103-00		RES., FXD, CMPSN: 10K OHM, 5%, 0.25W	01121	CB1035
A15R1504	315-0103-00		RES., FXD, CMPSN: 10K OHM, 5%, 0.25W	01121	CB1035
A15R1512	321-0383-08		RES., FXD, FILM: 95.3K OHM, 1%, 0.125W	24546	NC55C9532F
A15R1514	321-1625-06		RES., FXD, FILM: 277.8K OHM, 0.25%, 0.125W	91637	MFF1816C27780C
A15R1515	321-0249-09		RES., FXD, FILM: 3.83K OHM, 1%, 0.125W	91637	MFF1816C38300F
A15R1516	321-1625-06		RES., FXD, FILM: 277.8K OHM, 0.25%, 0.125W	91637	MFF1816C27780C
A15R1518	311-1558-00		RES., VAR, NONWIR: 20K OHM, 20%, 0.50W	73138	91-80-0
A15R1521	311-1566-00		RES., VAR, NONWIR: 200 OHM, 20%, 0.50W	73138	91-88-0
A15R1523	311-1559-00		RES., VAR, NONWIR: 10K OHM, 20%, 0.50W	73138	91A-10001M
A15R1526	321-0259-08		RES., FXD, FILM: 4.87K OHM, 1%, 0.125W	24546	NC55C4871F
A15R1527	321-0684-00		RES., FXD, FILM: 15K OHM, 0.5%, 0.125W	91637	MFF1816D15001D
A15R1531	311-1566-00		RES., VAR, NONWIR: 200 OHM, 20%, 0.50W	73138	91-88-0
A15R1532	315-0161-00		RES., FXD, CMPSN: 160 OHM, 5%, 0.25W	01121	CB1615
A15R1542	311-1555-00		RES., VAR, NONWIR: 100K OHM, 20%, 0.5W	73138	91-77-0
A15R1544	315-0683-00		RES., FXD, CMPSN: 68K OHM, 5%, 0.25W	01121	CB6835
A15R1545	321-0182-00		RES., FXD, FILM: 768 OHM, 1%, 0.125W	91637	MFF1816G768R0F
A15R1566	315-0684-00		RES., FXD, CMPSN: 680K OHM, 5%, 0.25W	01121	CB6845
A15R1623	315-0200-00		RES., FXD, CMPSN: 20 OHM, 5%, 0.25W	01121	CB2005
A15R1633	315-0103-00		RES., FXD, CMPSN: 10K OHM, 5%, 0.25W	01121	CB1035
A15R1762	315-0202-00		RES., FXD, CMPSN: 2K OHM, 5%, 0.25W	01121	CB2025
A15R1771	311-1566-00		RES., VAR, NONWIR: 200 OHM, 20%, 0.50W	73138	91-88-0
A15RT1522	307-0127-00		RES., THERMAL: 1K OHM, 10%	50157	2D1596
A15S2A-F	260-1951-00		SWITCH, PUSH: 6 BTN, 2/6 POLE, RANGE	80009	260-1951-00
A15T1721	120-1243-00		XFMR, PWR, STU:	80009	120-1243-00
A15U1126	156-0383-00		MICROCIRCUIT, DI: QUAD 2-INPUT NOR GATE	80009	156-0383-00
A15U1136	156-0382-00		MICROCIRCUIT, DI: QUAD 2-INPUT NAND GATE	80009	156-0382-00
A15U1146	156-0799-00		MICROCIRCUIT, DI: DECADE CNTR/DTV	80009	156-0799-00
A15U1156	156-0058-00		MICROCIRCUIT, DI: HEX. INVERTER	80009	156-0058-00
A15U1166	156-0385-00		MICROCIRCUIT, DI: HEX. INVERTER	80009	156-0385-00
A15U1201	156-1243-00		MICROCIRCUIT, DCTL: SEGMENT DECODER/DR	80009	156-1243-00
A15U1211	156-0724-01		MICROCIRCUIT, DCTL: HEX INVERTER	80009	156-0724-01
A15U1221	156-0058-00		MICROCIRCUIT, DI: HEX. INVERTER	80009	156-0058-00
A15U1231	156-0386-00		MICROCIRCUIT, DI: TRIPLE 3-INPUT NAND GATE	80009	156-0386-00
A15U1241	156-0382-00		MICROCIRCUIT, DI: QUAD 2-INPUT NAND GATE	80009	156-0382-00
A15U1251	156-0464-00		MICROCIRCUIT, DI: DUAL 4-INPUT NAND GATE	80009	156-0464-00
A15U1261	156-0382-00		MICROCIRCUIT, DI: QUAD 2-INPUT NAND GATE	80009	156-0382-00
A15U1300	156-0165-00		MICROCIRCUIT, DI: DUAL 4-INPUT POS NOR GATE	01295	SN7425N
A15U1311	156-0476-00		MICROCIRCUIT, DI: DIG SECT OF A/D SYSTEM	17856	LD110CJ
A15U1321	156-0875-00		MICROCIRCUIT, DI: DUAL 2 WIDE 2INP AO1 GATE	80009	156-0875-00
A15U1331	156-0382-00		MICROCIRCUIT, DI: QUAD 2-INPUT NAND GATE	80009	156-0382-00
A15U1341	156-0464-00		MICROCIRCUIT, DI: DUAL 4-INPUT NAND GATE	80009	156-0464-00
A15U1351	156-0382-00		MICROCIRCUIT, DI: QUAD 2-INPUT NAND GATE	80009	156-0382-00
A15U1361	156-1245-00		MICROCIRCUIT, LI: 7 XSTR, HV/HIGH CUR	80009	156-1245-00
A15U1400	156-0970-00		MICROCIRCUIT, DI: QUAD HV NAND GATE W/OC OUT	80009	156-0970-00
A15U1411	156-0718-00		MICROCIRCUIT, DI: TRIPLE 3-INP POS-NOR GATES	80009	156-0718-00
A15U1421	156-0382-00		MICROCIRCUIT, DI: QUAD 2-INPUT NAND GATE	80009	156-0382-00
A15U1431	156-0386-00		MICROCIRCUIT, DI: TRIPLE 3-INPUT NAND GATE	80009	156-0386-00
A15U1461	156-1268-00		MICROCIRCUIT, LI: A/D CONVERTER	80009	156-1268-00
A15U1501	156-0644-00		MICROCIRCUIT, DI: QUAD BILATERAL SWITCH	80009	156-0644-00
A15U1611	156-0402-00		MICROCIRCUIT, LI: TIMER	27014	SL34829
A15U1651	156-0277-00		MICROCIRCUIT, LI: VOLTAGE REGULATOR	80009	156-0277-00
A15U1655	156-1262-00		MICROCIRCUIT, LI: VOLTAGE REGULATOR	80009	156-1262-00
A15U1754	156-0872-00		MICROCIRCUIT, LI: VOLTAGE REGULATOR	80009	156-0872-00
A15VR1451	152-0168-00		SEMICONV DEVICE: ZENER, 0.4W, 12V, 5%	80009	152-0168-00
A15VR1565	152-0317-00		SEMICONV DEVICE: ZENER, 0.25W, 6.2V, 5%	80009	152-0317-00

DIAGRAMS AND CIRCUIT BOARD ILLUSTRATIONS

Symbols

Graphic symbols and class designation letters are based on ANSI Standard Y32.2-1975.

Logic symbology is based on ANSI Y32.14-1973 in terms of positive logic. Logic symbols depict the logic function performed and may differ from the manufacturer's data.

The overline on a signal name indicates that the signal performs its intended function when it is in the low state.

Abbreviations are based on ANSI Y1.1-1972.

Other ANSI standards that are used in the preparation of diagrams by Tektronix, Inc. are:

- Y14.15, 1966 Drafting Practices.
- Y14.2, 1973 Line Conventions and Lettering.
- Y10.5, 1968 Letter Symbols for Quantities Used in Electrical Science and Electrical Engineering.

American National Standard Institute
1430 Broadway
New York, New York 10018

Component Values

Electrical components shown on the diagrams are in the following units unless noted otherwise:

Capacitors = Values one or greater are in picofarads (pF).
Values less than one are in microfarads (μ F).

Resistors = Ohms (Ω).

The following special symbols may appear on the diagrams:

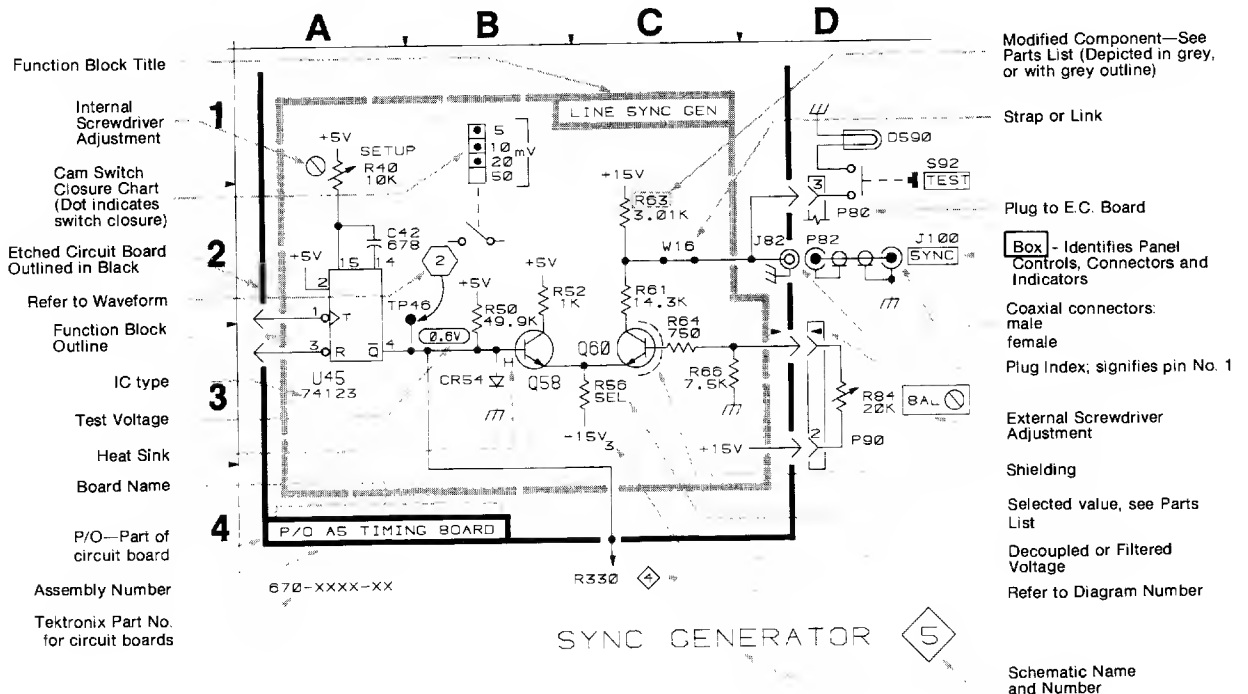

Assembly Numbers and Grid Coordinates

Each assembly in the instrument is assigned an assembly number (e.g., A20). The assembly number appears on the circuit board outline on the diagram, in the title for the circuit board component location illustration, and in the lookup table for the schematic diagram and corresponding component locator illustration. The Replaceable Electrical Parts list is arranged by assemblies in numerical sequence; the components are listed by component number (see following illustration for constructing a component number).

COMPONENT NUMBER EXAMPLE

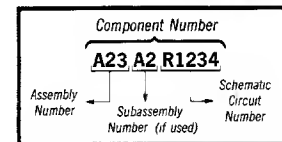

Chassis-mounted components have no Assembly Number prefix—see end of Replaceable Electrical Parts List

The schematic diagram and circuit board component location illustration have grids. A lookup table with the grid coordinates is provided for ease of locating the component. Only the components illustrated on the facing diagram are listed in the lookup table. When more than one schematic diagram is used to illustrate the circuitry on a circuit board, the circuit board illustration may only appear opposite the first diagram on which it was illustrated; the lookup table will list the diagram number of other diagrams that the circuitry of the circuit board appears on.

COORDINATES

Coordinates

Each component is assigned an assembly number. The assembly number is shown on the diagram, in the next location illustration, in the schematic diagram and in the locator illustration. The diagram is arranged by assemblies and components are listed by assembly number (see following illustration for example).

EXAMPLE

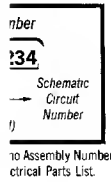

This diagram is a circuit board component diagram. A lookup table with the component numbers for ease of locating the components is illustrated on the facing page. When more than one component is illustrated on the same circuit board, the diagram number of the circuit board is indicated by the diagram number of the circuit board.

- Modified Component—See Parts List (Depicted in grey, or with grey outline)
- Strap or Link
- Plug to E.C. Board
- Box - Identifies Panel Controls, Connectors and Indicators
- Coaxial connectors: male female
- Plug Index; signifies pin No. 1
- External Screwdriver Adjustment
- Shielding
- Selected value, see Parts List
- Decoupled or Filtered Voltage
- Refer to Diagram Number
- Schematic Name and Number

DM 502A BLOCK DIAGRAM

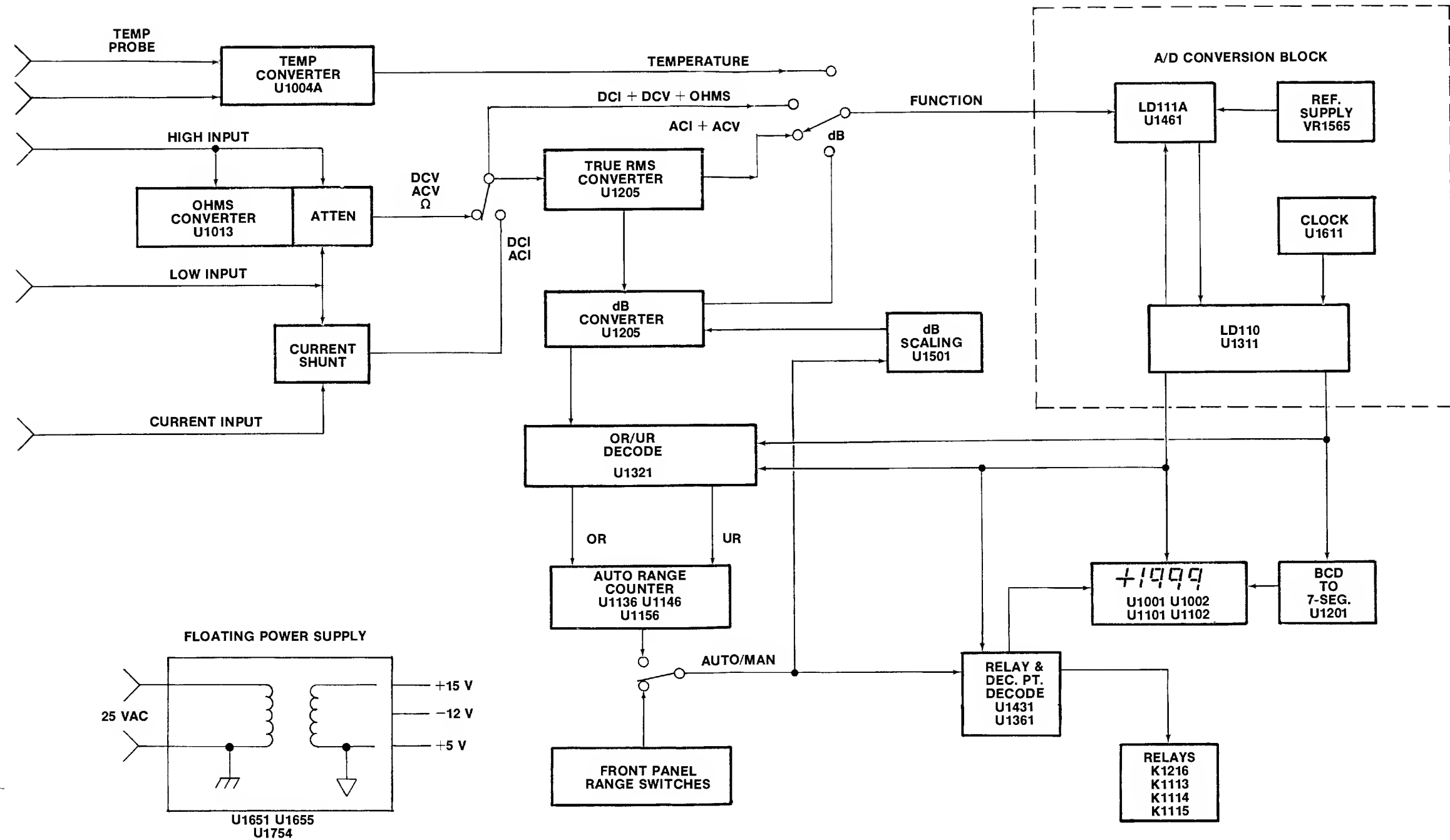
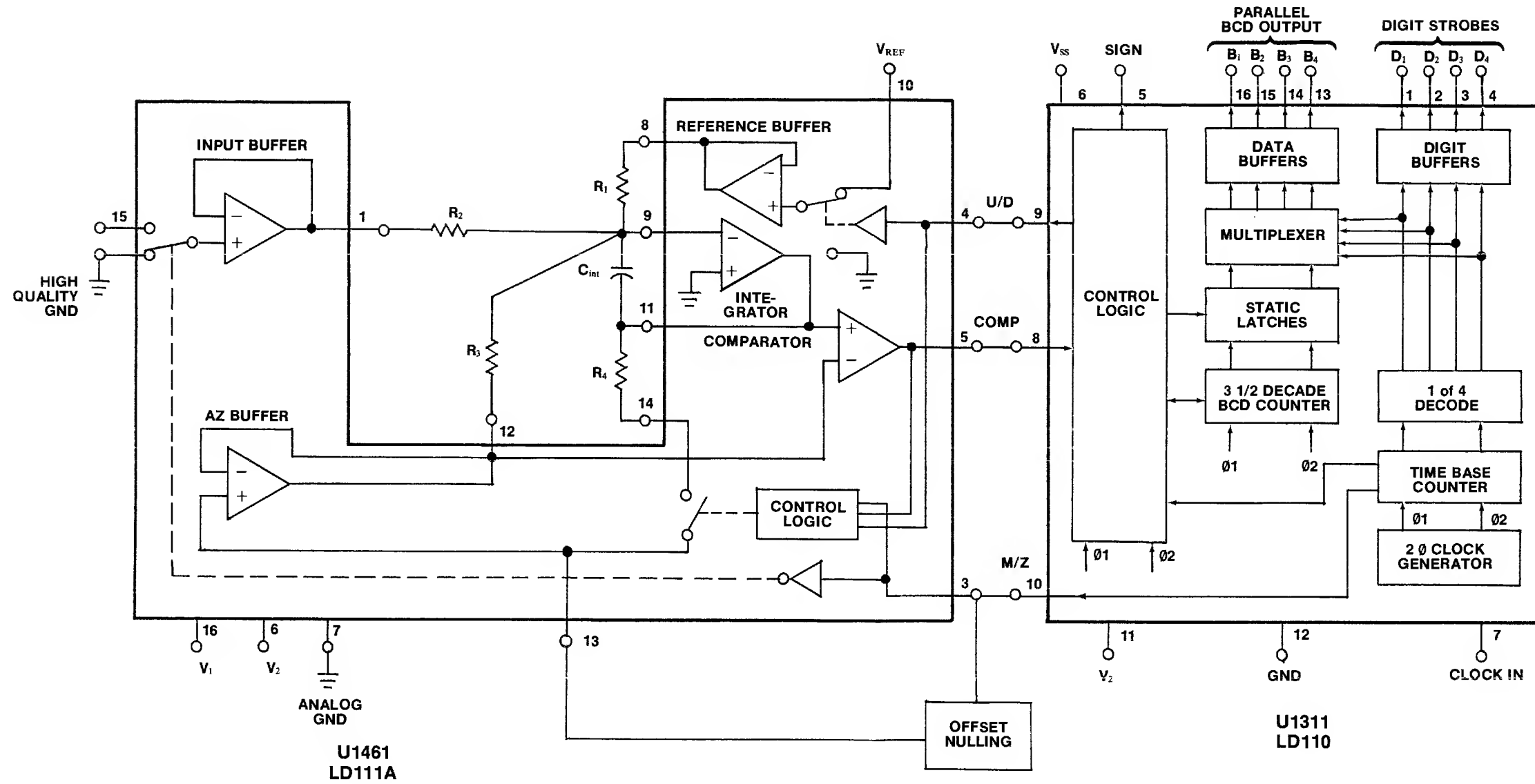

Fig. 8-1

ANALOG TO DIGITAL CONVERTER BLOCK DIAGRAM



- $R_1 = R1458, R1443$
- $R_2 = R1457$
- $C_{int} = C1432$
- $R_4 = R1453$
- $R_3 = R1455$

Fig. 8-2

ADJUSTMENT LOCATIONS

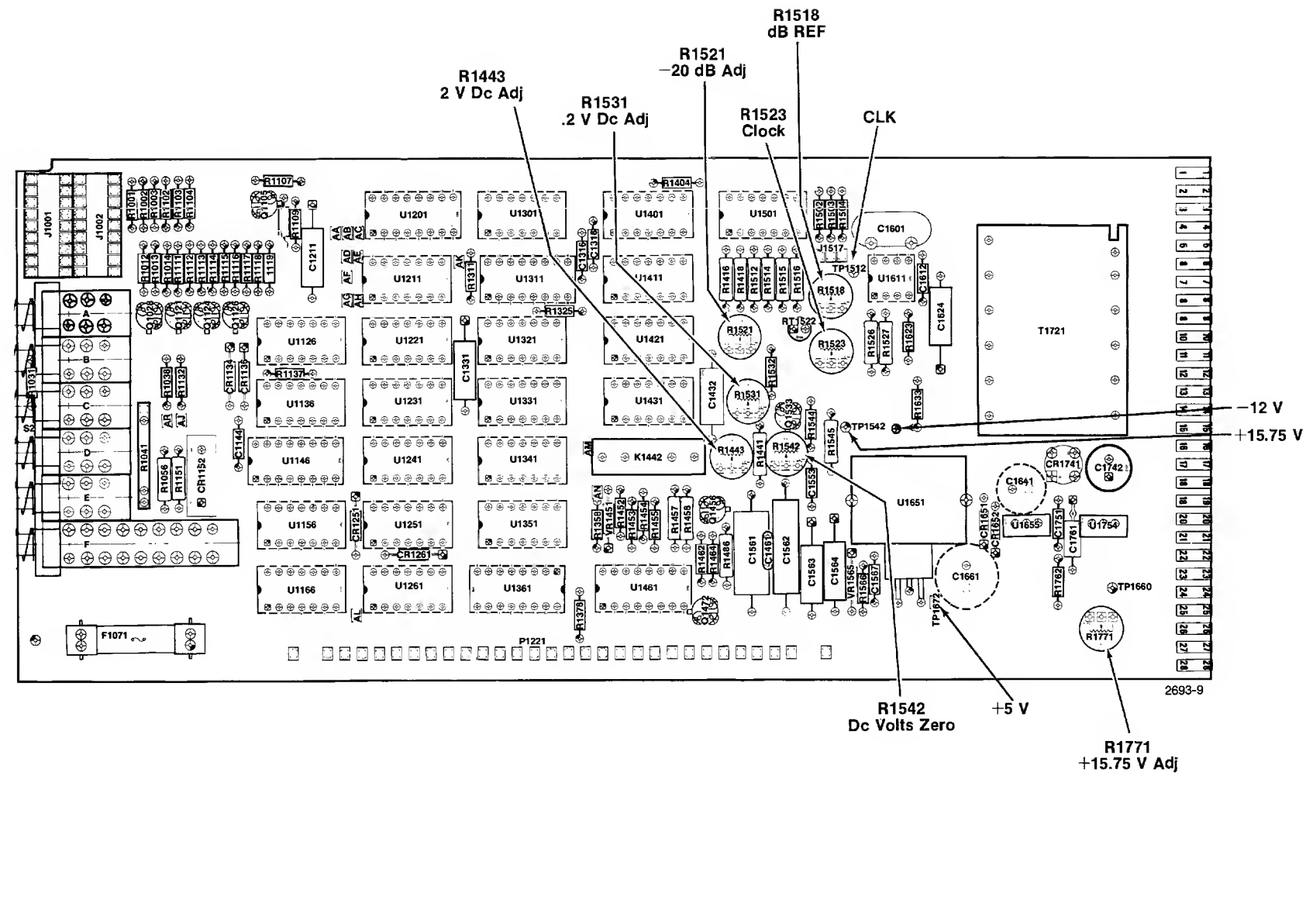

Fig. 8-3. Main Board

ADJUSTMENT LOCATIONS

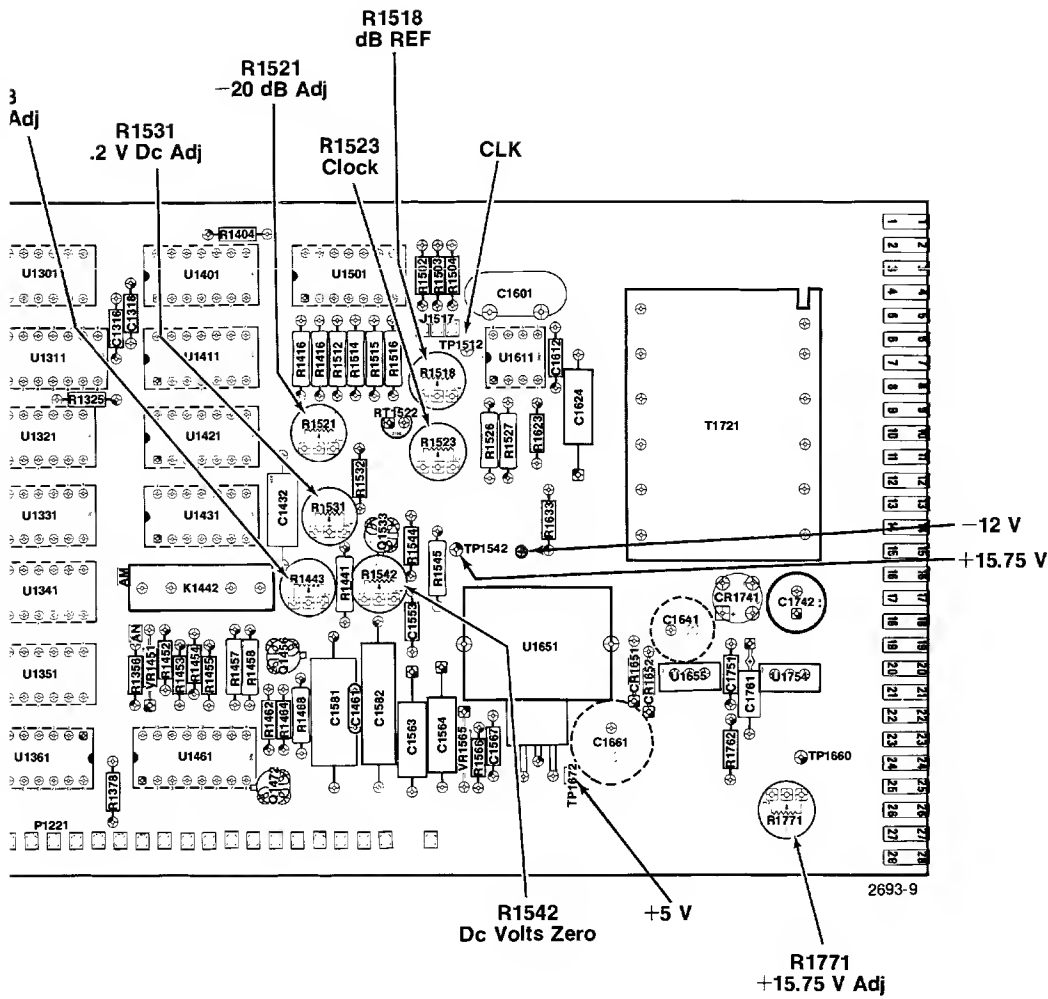

Fig. 8-3. Main Board

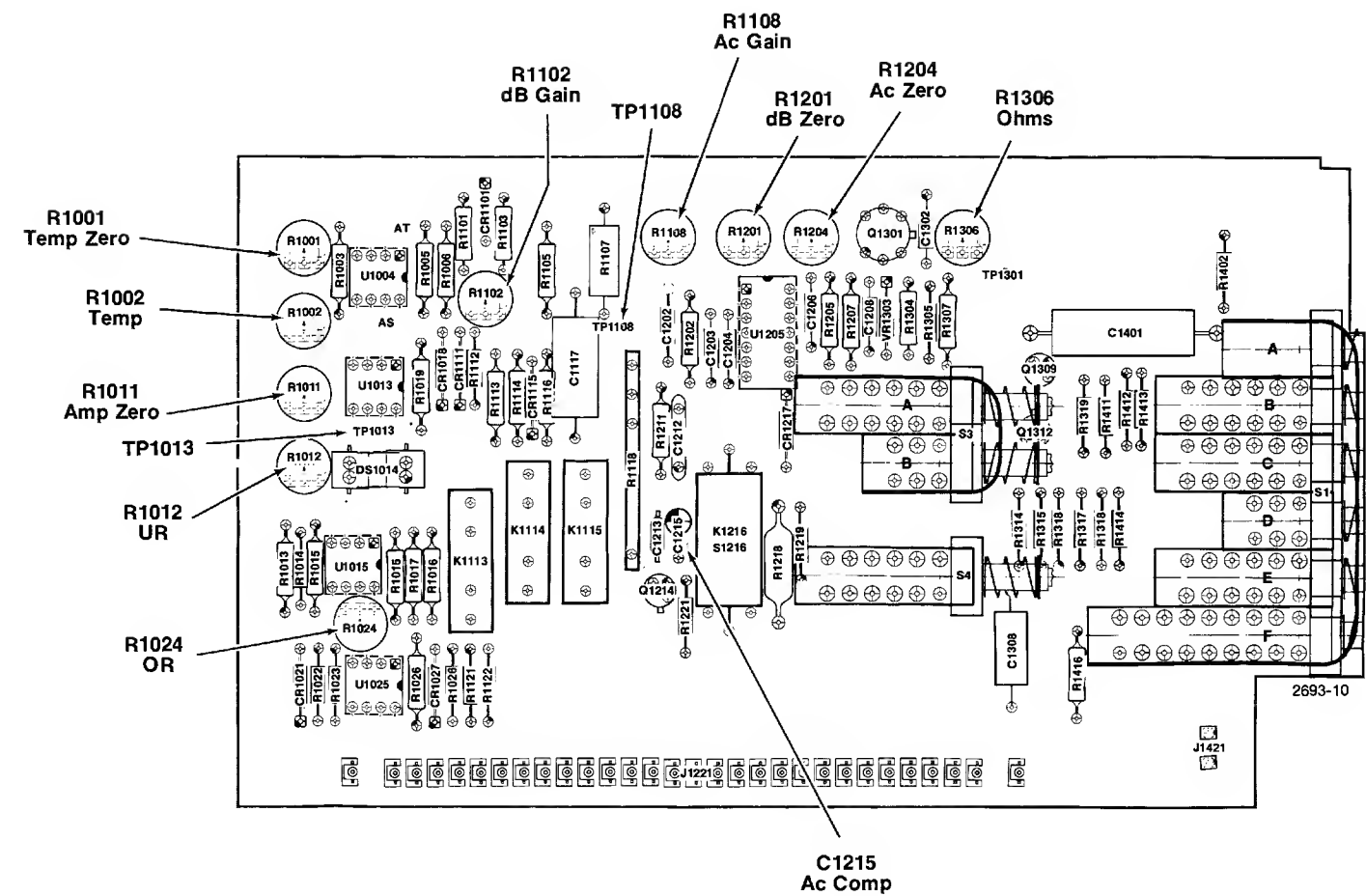

Fig. 8-4. Analog Board

REAR INTERFACE CONNECTIONS

Table 8-1
REAR INTERFACE CONNECTOR ASSIGNMENTS

Remarks	Maximum Recommended Loads	Active Level	Output or Input	Pin B		Pin A	Output Input	Active Level	Maximum Recommended Loads	Remarks	
			HIGH Input	*28	DM barrier slot	28*	LOW input				
				27		27					
				26		26					
				25		25					
				24		24					
				23		23					
				22		22					
				21		21					
				20		20					
				19		19					
				18	18						
				17	TM 500 barrier slot	17					
				16		16					
				15		15					
				14		14					
			25 V ac winding	*13		13*	25 V ac winding				
			+33.5 V filtered dc	12		12	+33.5 V filtered dc				
			Collector lead of pnp series-pass	11		11	Base lead of pnp series-pass				
			Transformer shield	10		10	Emitter lead of pnp series-pass				
			±33.5 V common return	*9		9*	±33.5 V common return				
			-33.5 V filtered dc	8		8	-33.5 V filtered dc				
			Collector lead of npn series-pass	7	7	Emitter lead of npn series-pass					
			No connection	6	6	Base lead of npn series-pass					
			17.5 V ac winding	5	5	17.5 V ac winding					
			+11.5 V common return	4	4	+11.5 V common return					
			+11.5 V common return	3	3	+11.5 V common return					
			+11.5 V filtered dc	2	2	+11.5 V filtered dc					
			25 V ac winding	1	1	25 V ac winding					
				B		A					

Rear view of plug-in

Functions Available at Rear Connector

A slot between pins 17 and 18 on the rear connector identifies the DM 502A as a member of the digital multimeter family. Insert a barrier in the corresponding position of the power module jack to prevent other than signal source plug-ins from being used in that compartment. This protects the plug-in if specialized connections are made to that compartment. Consult the Building a System section of the power module manual for further information. Signal outputs, or other specialized connections, may be made to the rear interface connectors as shown in the input-output assignments illustration in Table 8-1. A description of these connections follows.

High and Low Input (contacts 28B and 28A)

Measurement signals, except temperature and current, can be applied directly through the rear interface circuit board contacts. Comparisons can be made between front panel and rear interface measurement sources by using the EXT INT pushbutton located on the front panel. Do not exceed the maximum specified input voltage listed in the Specification section. Also note that some functions when applied at the rear interface inputs are derated. This information is also noted in the Specification section.

Assignments listed for pins 1A—13A and 1B—13B are available in all power modules; however only those pins marked with an asterisk (*) are used in the DM 502A.

Power Supply

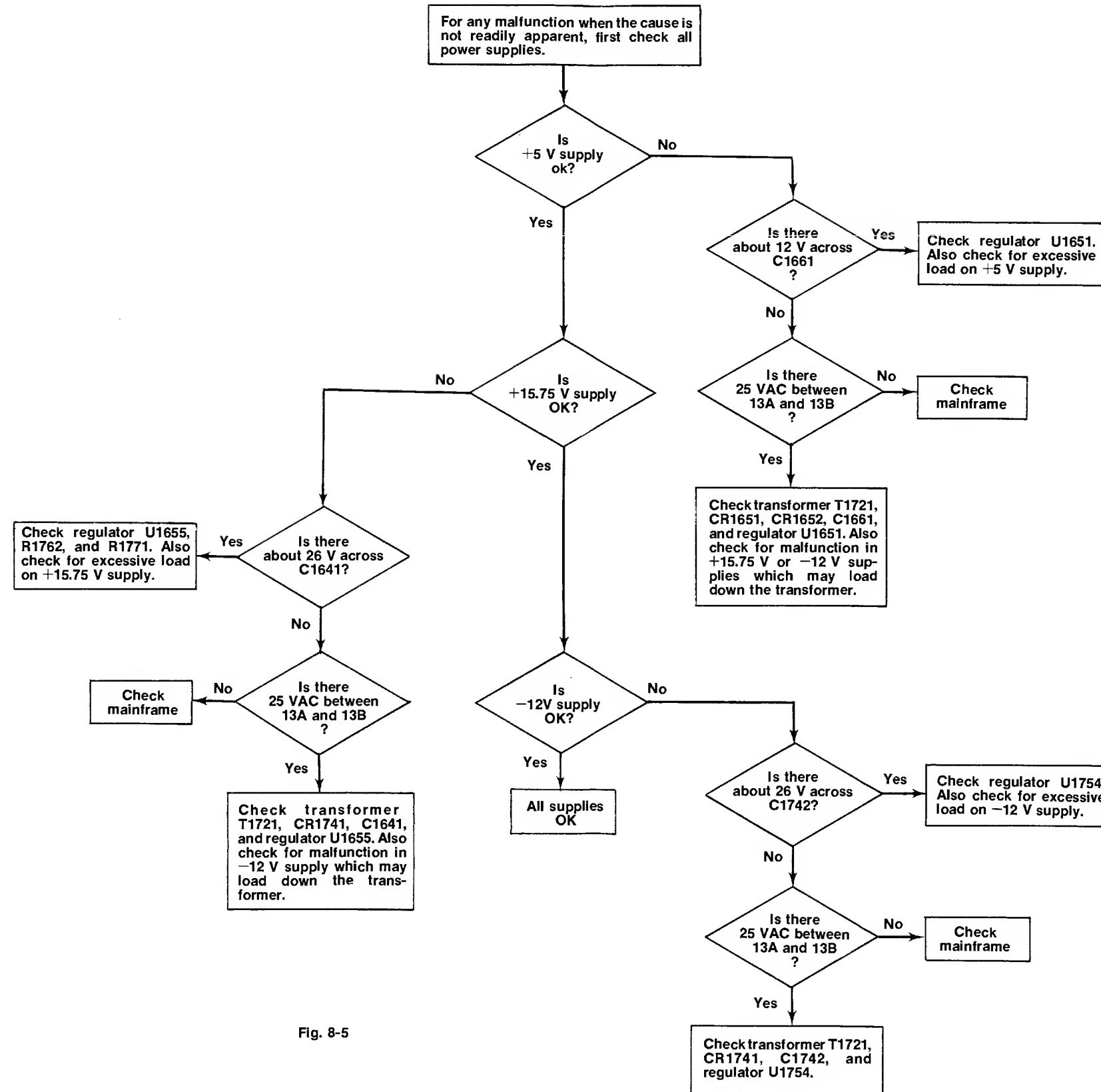

Fig. 8-5

DC VOLTS

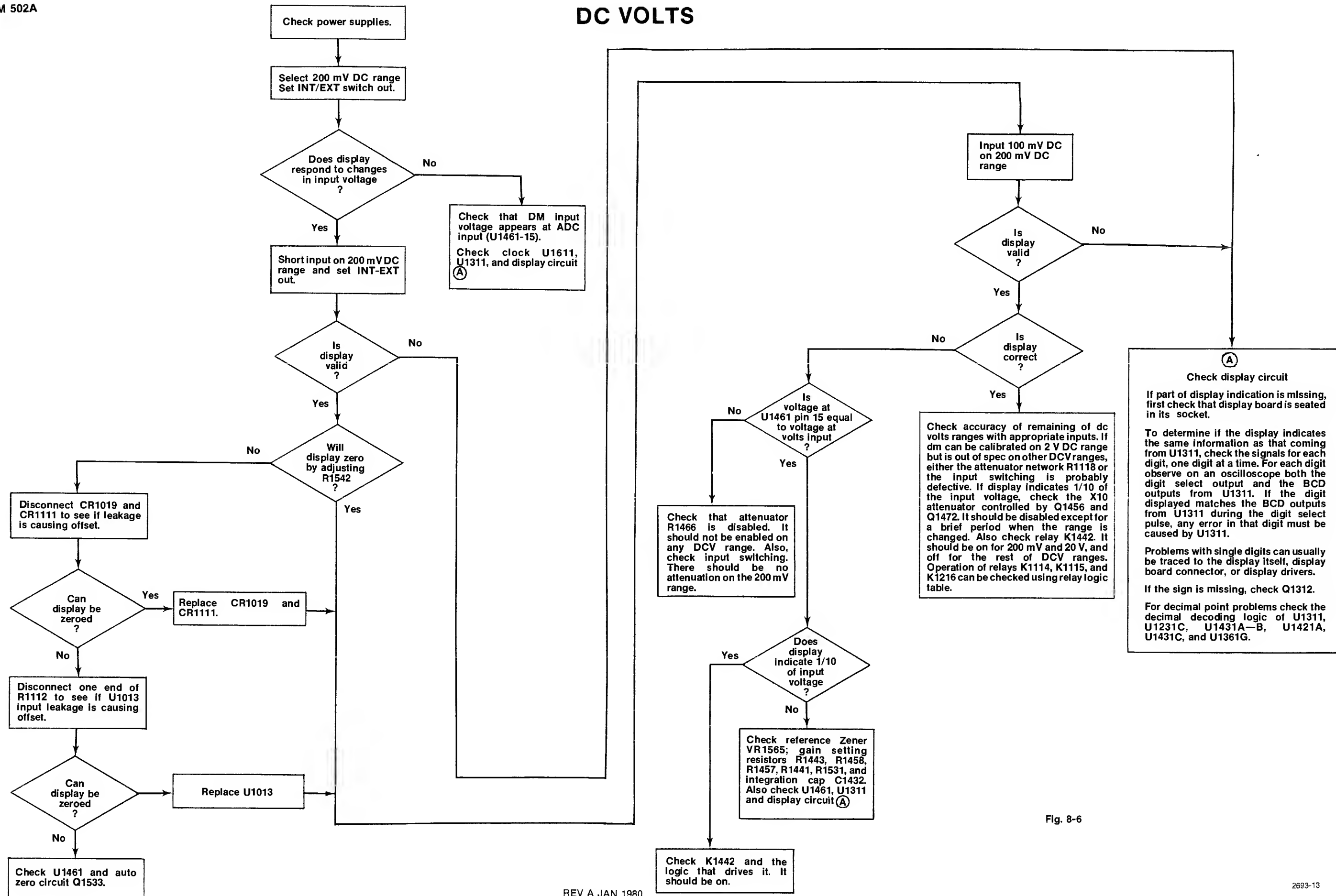

Fig. 8-6

DC CURRENT

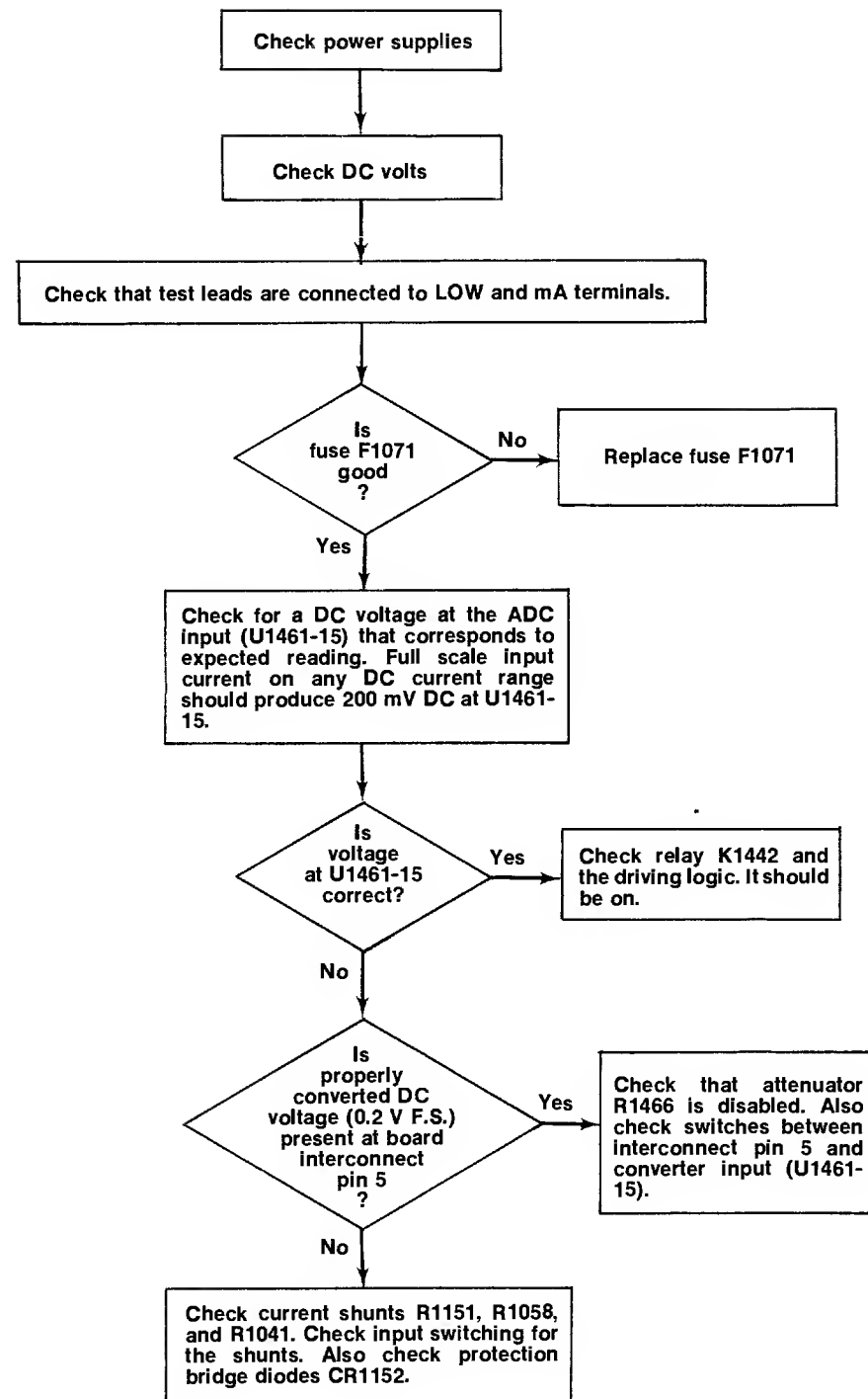

Fig. 8-7

2693-14

REV A JAN 1980

OHMS

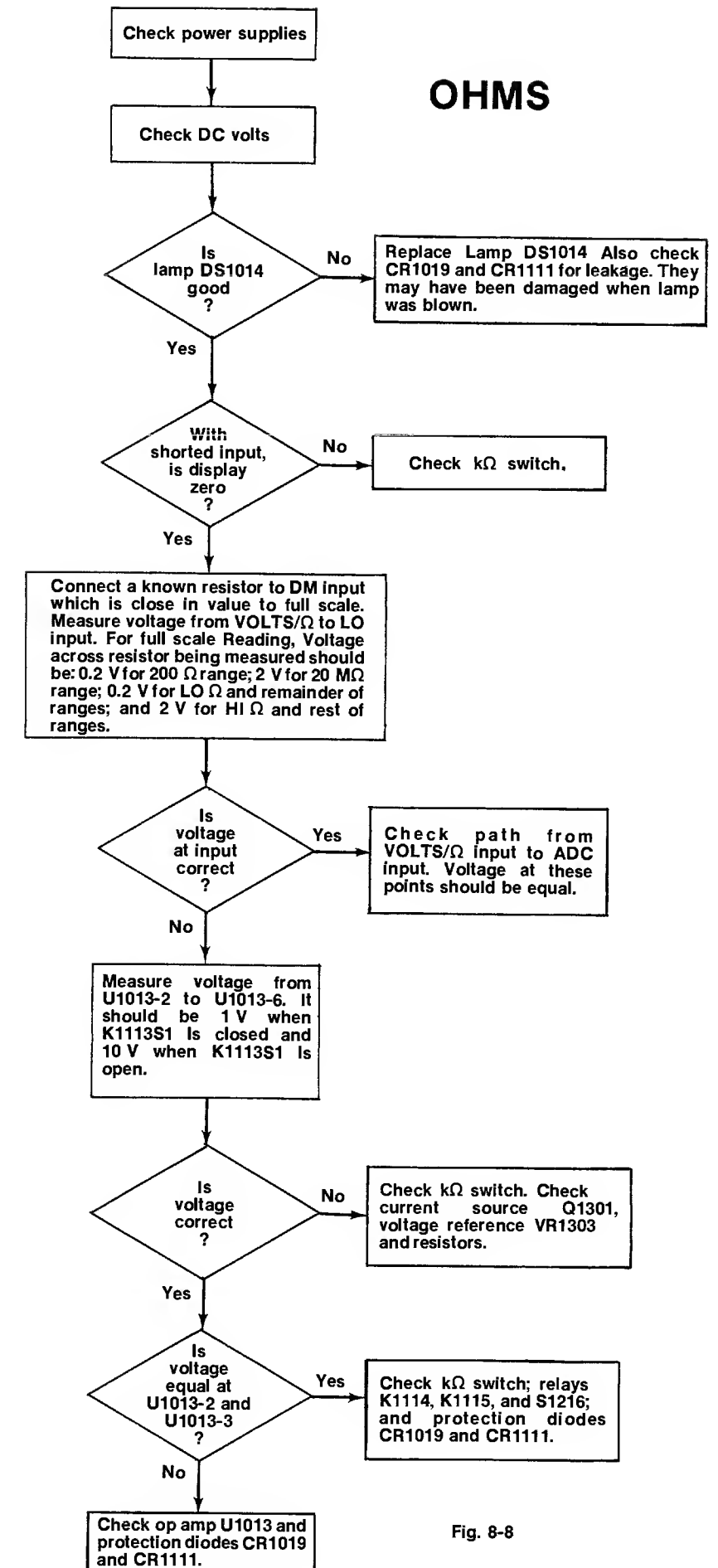

Fig. 8-8

2693-15

AC VOLTS

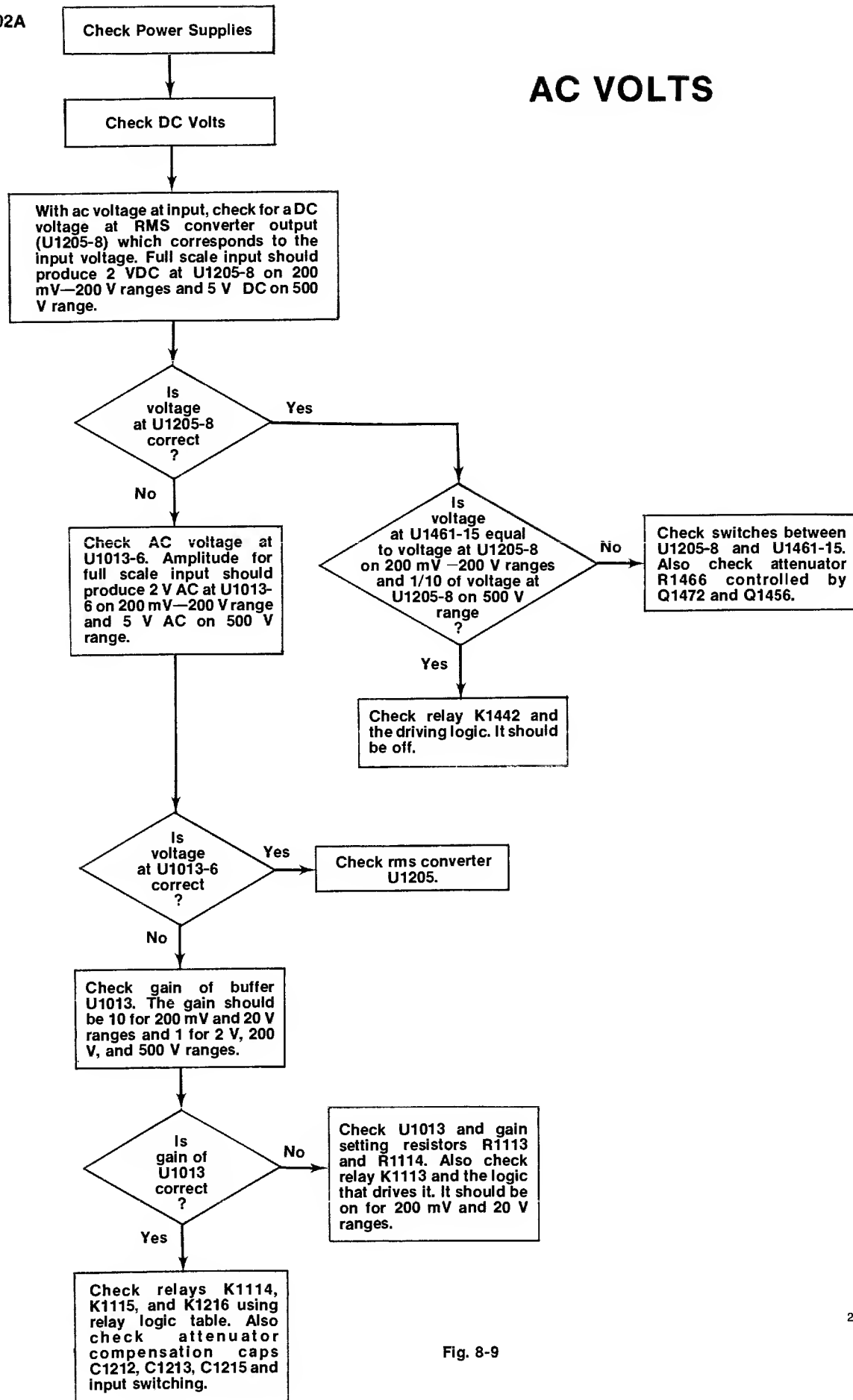

Fig. 8-9

2693-16

AC CURRENT

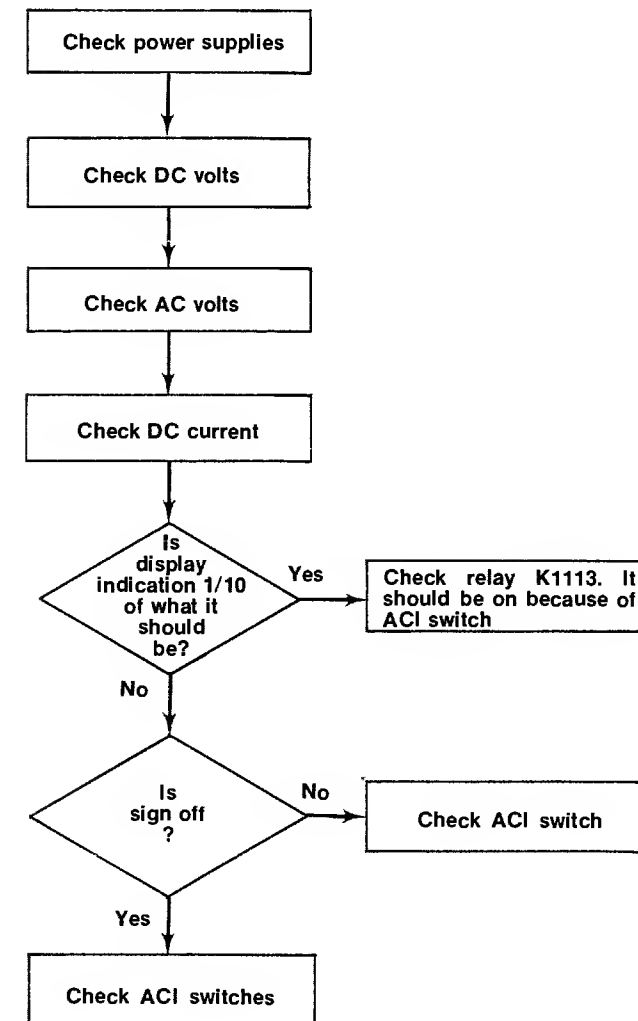
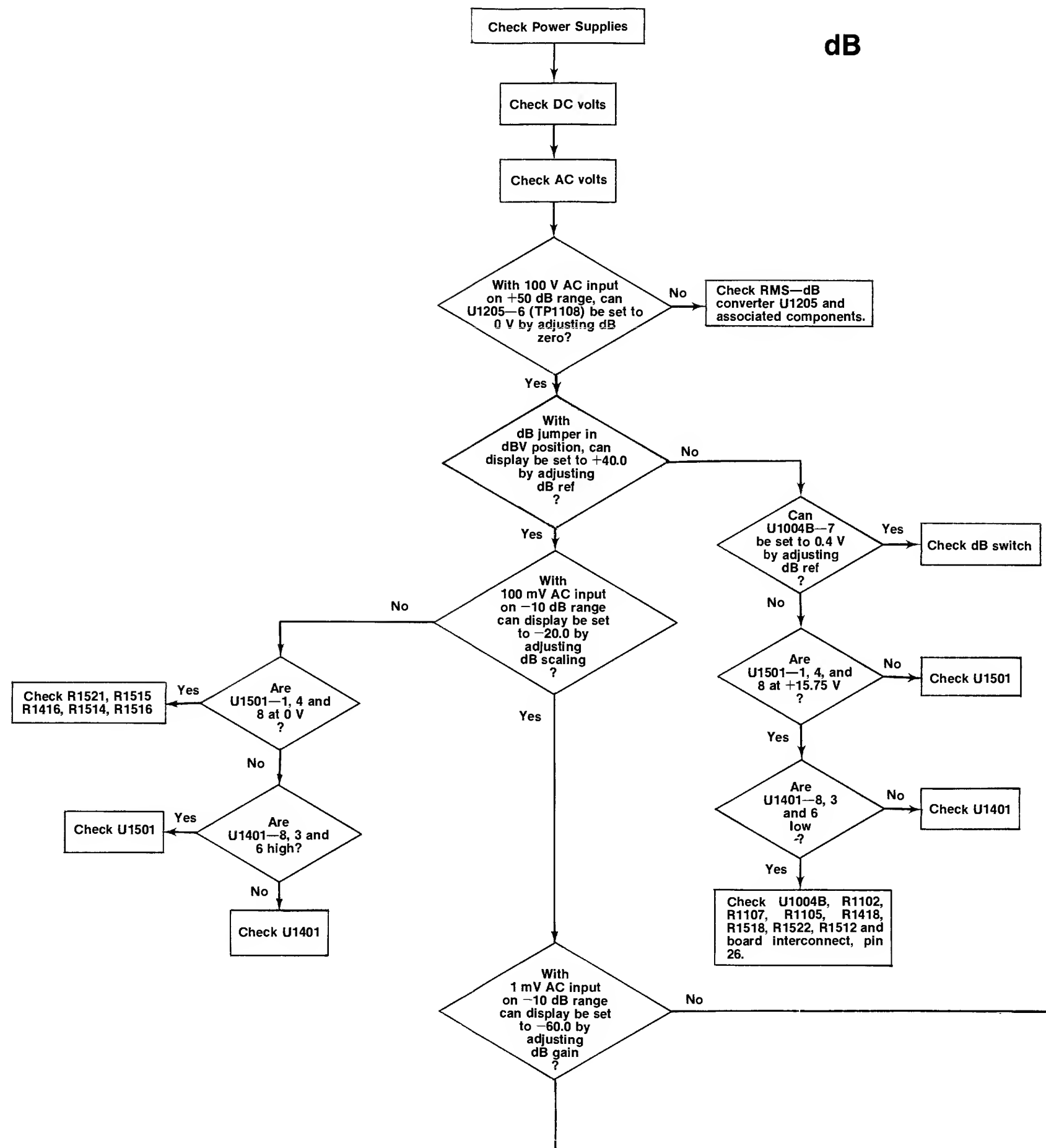

Fig. 8-10

2693-17



dB

Check U1401 at range U1401-8 and U1501-1 and +30 dB range U1401-8 and U1501-8 sh

Check U1025A. Pin 1 should go high at ≈13 V when TP1108 goes below -0.04 V.

Check U1027. Pin 7 should go high when TP1108 goes above 0.09 V.

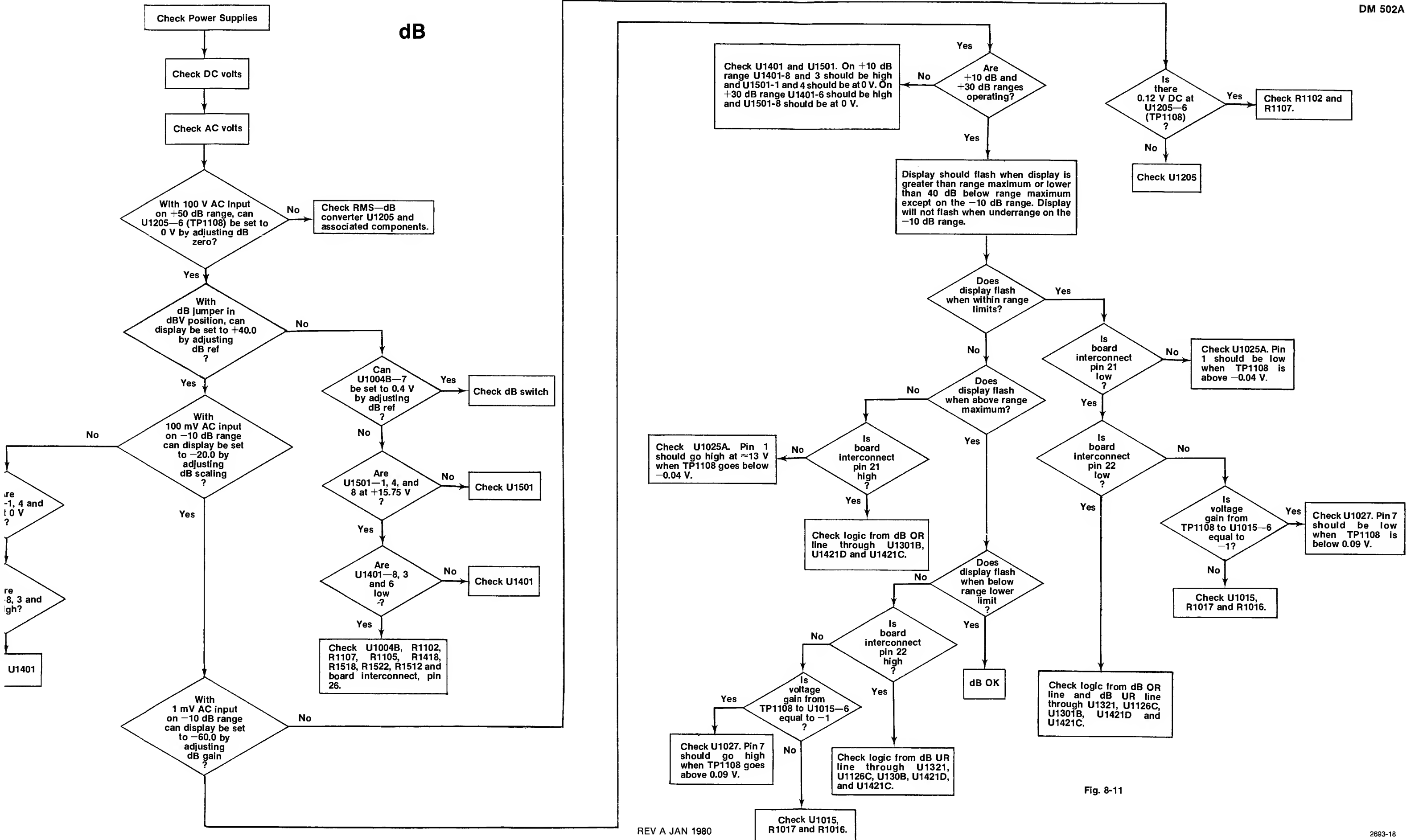

Fig. 8-11

TEMPERATURE

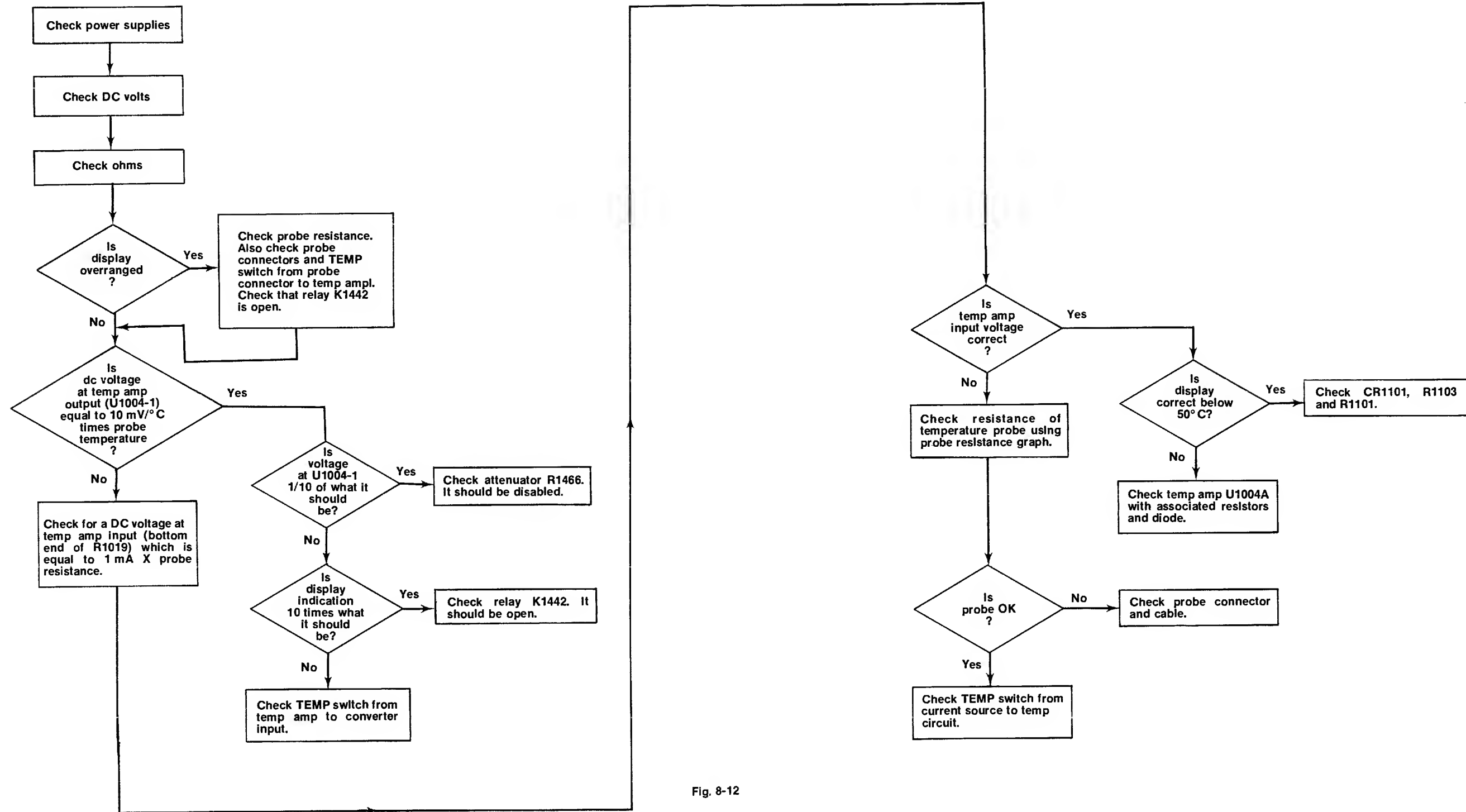

Fig. 8-12

AUTO-RANGE

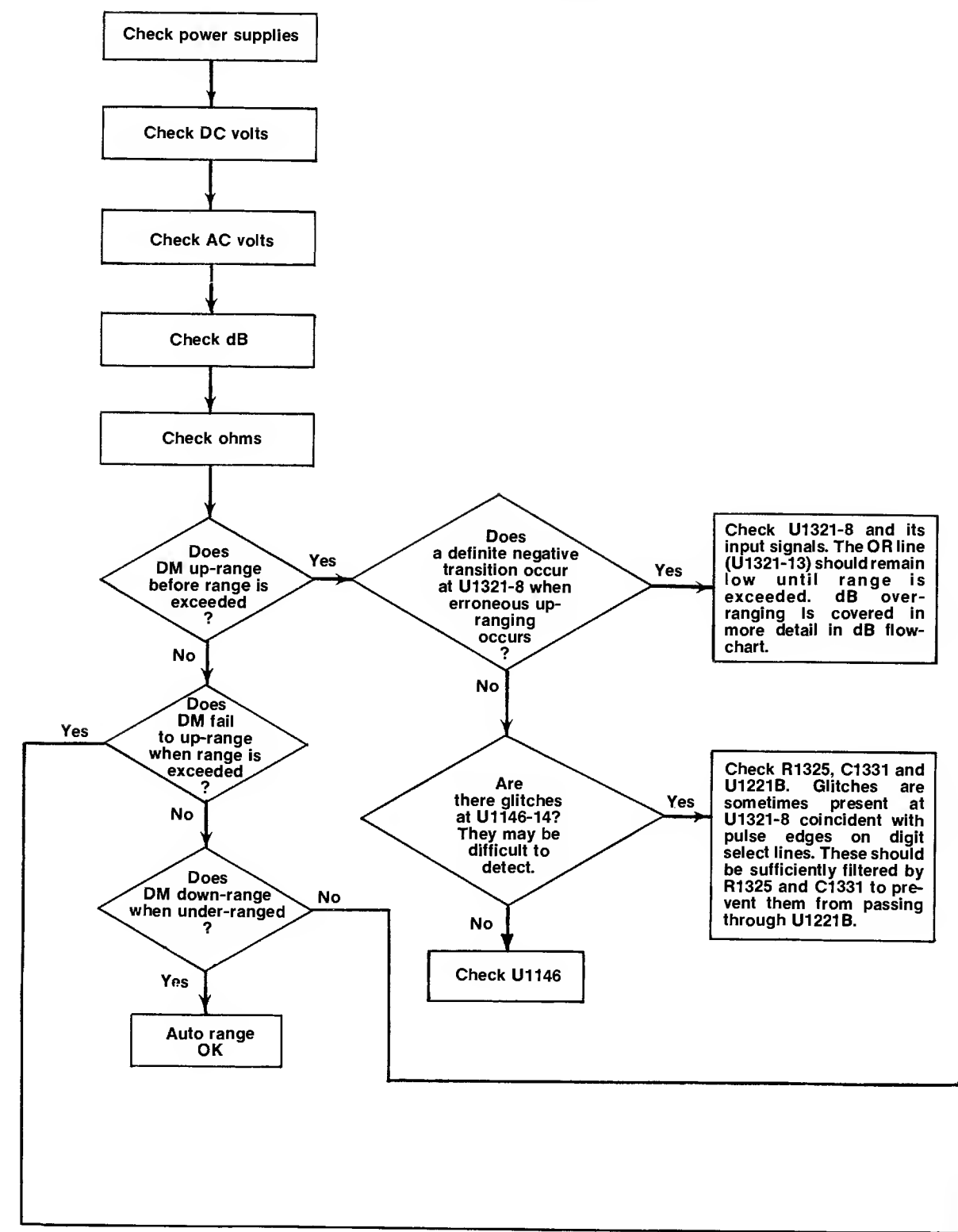
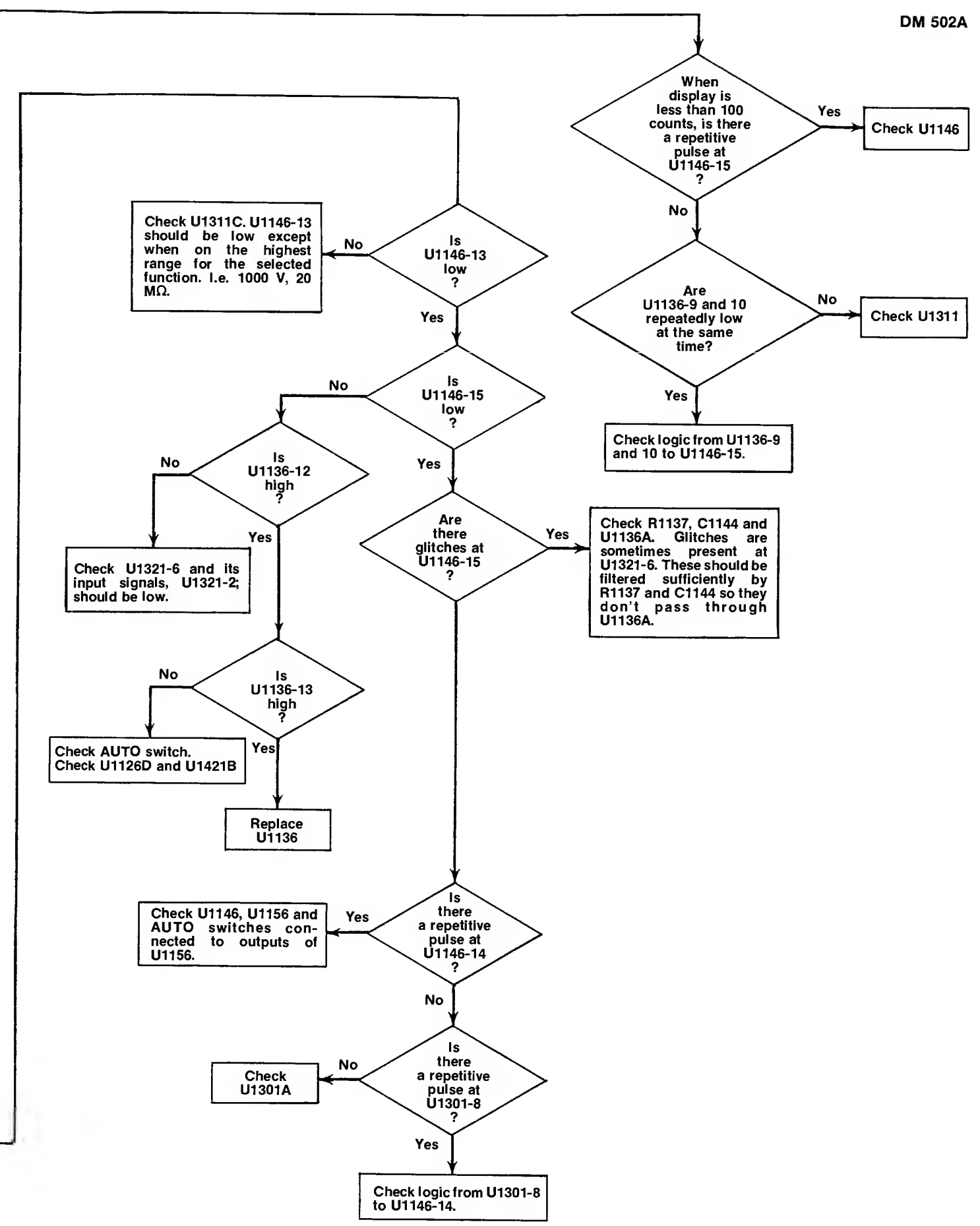
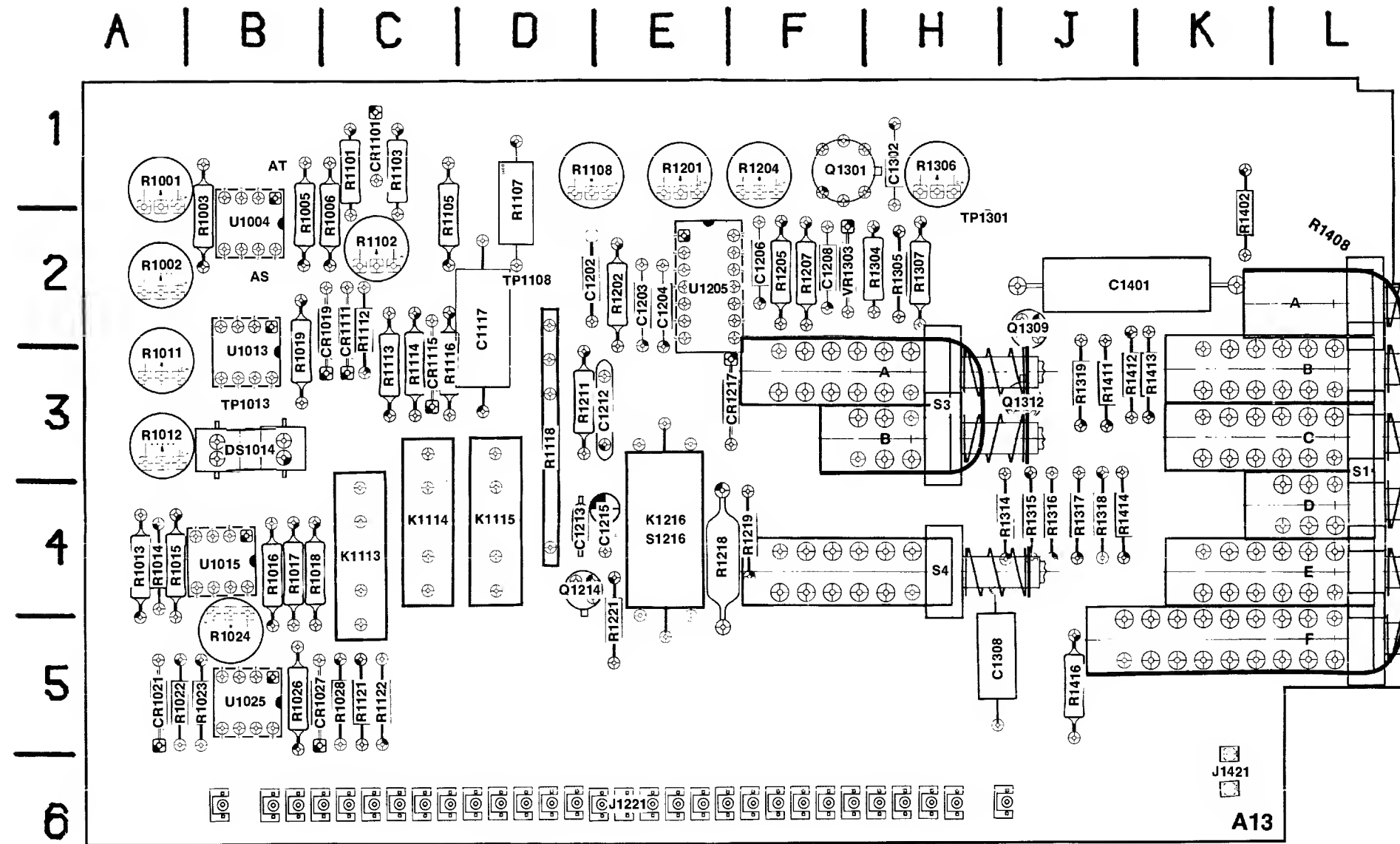

Fig. 8-13



PARTS LOCATION GRID



2693-21

Fig. 8-14. Analog Board (A13).

Static Sensitive Devices
See Maintenance Section

COMPONENT NUMBER EXAMPLE

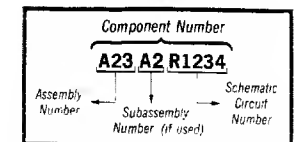

Chassis-mounted components have no Assembly Number prefix—see end of Replacable Electrical Parts List.

P/O	Circuit Number
	C1117
	C1202
	C1204
	C1206
	C1208
	C1212
	C1213
	C1215
	C1302
	C1308
	C1401
	CR1019
	CR1101
	CR1111
	CR1115
	CR1217
	CR1408
	DS1014
	J5
	J500
	J510
	J520
	J530
	J1221
	J1421
	K1113
	K1114
	K1115
	K1216
	P1221
	P1421
	Q1214
	Q1301
	Q1309
	Q1312
	R1001
	P/O A15
	CR1152
	F1071

ATION GRID

| F | H | J | K | L |

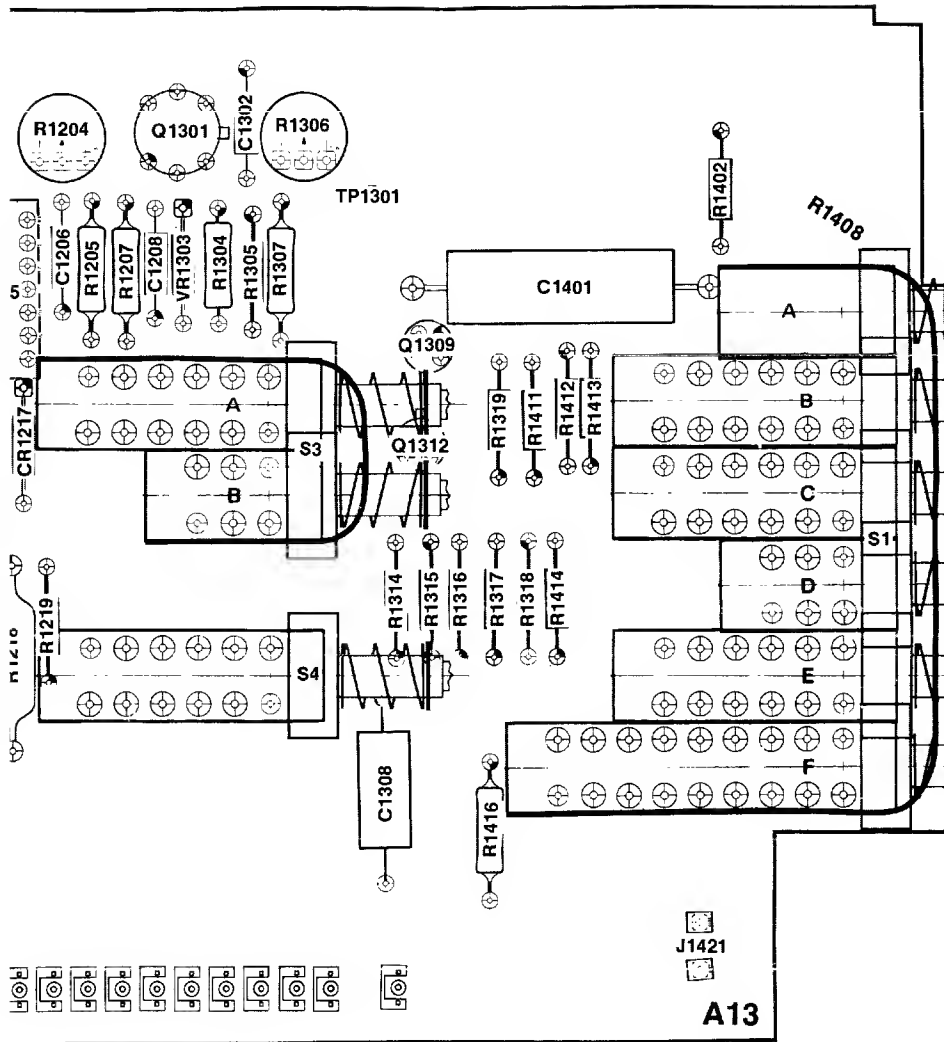

2693-21

g Board (A13).

⊗ Static Sensitive Devices
See Maintenance Section

COMPONENT NUMBER EXAMPLE

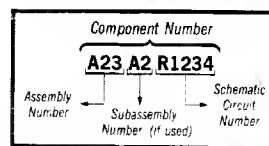

Chassis-mounted components have no Assembly Number prefix—see end of Replaceable Electrical Parts List

REV A JAN 1980

Table 8-2
COMPONENT
REFERENCE
CHART

P/O A13 ASSY						INPUT CIRCUITRY ①		
Circuit Number	Schematic Location	Board Location	Circuit Number	Schematic Location	Board Location	Circuit Number	Schematic Location	Board Location
C1117	H7	D3	R1002	K7	A2	S1-B	F3	L3
C1202	J5	D2	R1003	H8	B2	S1-B	F5	L3
C1204	L5	E2	R1005	J7	B2	S1-B	H2	L3
C1206	J6	F2	R1006	K7	C2	S1-B	L7	L3
C1208	C8	F2	R1011	E7	A3	S1-C	K1	L3
C1212	H6	E3	R1019	J8	B3	S1-C	F7	L3
C1213	H5	D4	R1101	K8	C1	S1-C	E7	L3
C1215	H5	E4	R1103	K7	C1	S1-C	C5	L3
C1302	H8	H1	R1108	J7	D1	S1-D	J4	L4
C1308	M6	J5	R1112	D7	C3	S1-D	C7	L4
C1401	F5	J2	R1113	E8	C3	S1-E	F4	L4
CR1019	D7	C3	R1114	F7	C3	S1-E	C7	L4
CR1101	L7	C1	R1116	F6	C3	S1-E	E2	L4
CR1111	D7	C3	R1118A	F6	D3	S1-E	L7	L4
CR1115	F4	C3	R1118B	F6	D3	S1-F	H8	L5
CR1217	L3	F3	R1118C	F6	D3	S1-F	J8	L5
CR1408	F7	L2	R1201	J5	E1	S1-F	L6	L5
DS1014	C7	B3	R1202	J5	E2	S1-F	D2	L5
J5	A1	Chassis	R1204	H6	F1	S1-F	C6	L5
J500	B8	Chassis	R1205	J6	F2	S3-A	H2	H3
J510	B2	Chassis	R1207	J6	F2	S3-A	L7	H3
J520	B2	Chassis	R1211	E6	D3	S3-A	J2	H3
J530	B3	Chassis	R1218	F5	E4	S3-A	M8	H3
J1221	M3	E6	R1219	F5	F4	S3-B	B6	H4
J1421	B8	K6	R1221	E2	E5	S4	B5	H4
K1113	H4	C4	R1304	C7	H2	S4	B7	H4
K1114	E4	C4	R1305	C7	H2	S4	B7	H4
K1115	E4	D4	R1306	D8	H1	S1216	E5	E4
K1216	E4	E4	R1307	D7	H2	TP1013	H7	B3
P1221	M3	H6	R1314	E1	J4	TP1108	L6	D2
P1421	A8	Chassis	R1315	F1	J4	TP1301	B8	H2
Q1214	F2	D5	R1316	E1	J4	U1004A	K8	B2
Q1301	D7	F1	R1317	L4	J4	U1013	E7	B3
Q1309	K3	J2	R1318	K1	J4	U1205	J5	E2
Q1312	F2	J3	R1319	K2	J3	VR1303	C8	F2
R1001	H7	A1	R1402	J3	K2			
			R1411	J2	J3			
			R1412	H2	J3			
			R1413	H2	K3			
			R1414	J3	J4			
			R1416	L6	J5			

P/O A13 Assy also shown on ②

P/O A15 ASSY Refer to Fig. 8-15						INPUT CIRCUITRY ①		
Circuit Number	Schematic Location	Board Location	Circuit Number	Schematic Location	Board Location	Circuit Number	Schematic Location	Board Location
CR1152	C3	C4	R1041A	C2	B4	S2-B	C1	A3
F1071	B2	B6	R1041B	C2	B4	S2-C	C1	A3
			R1041C	C2	B4	S2-D	B2	A4
			R1058	C1	B4	S2-E	B2	A4
			R1151	C1	B4			

P/O A15 ASSY also shown on ② ③ ④

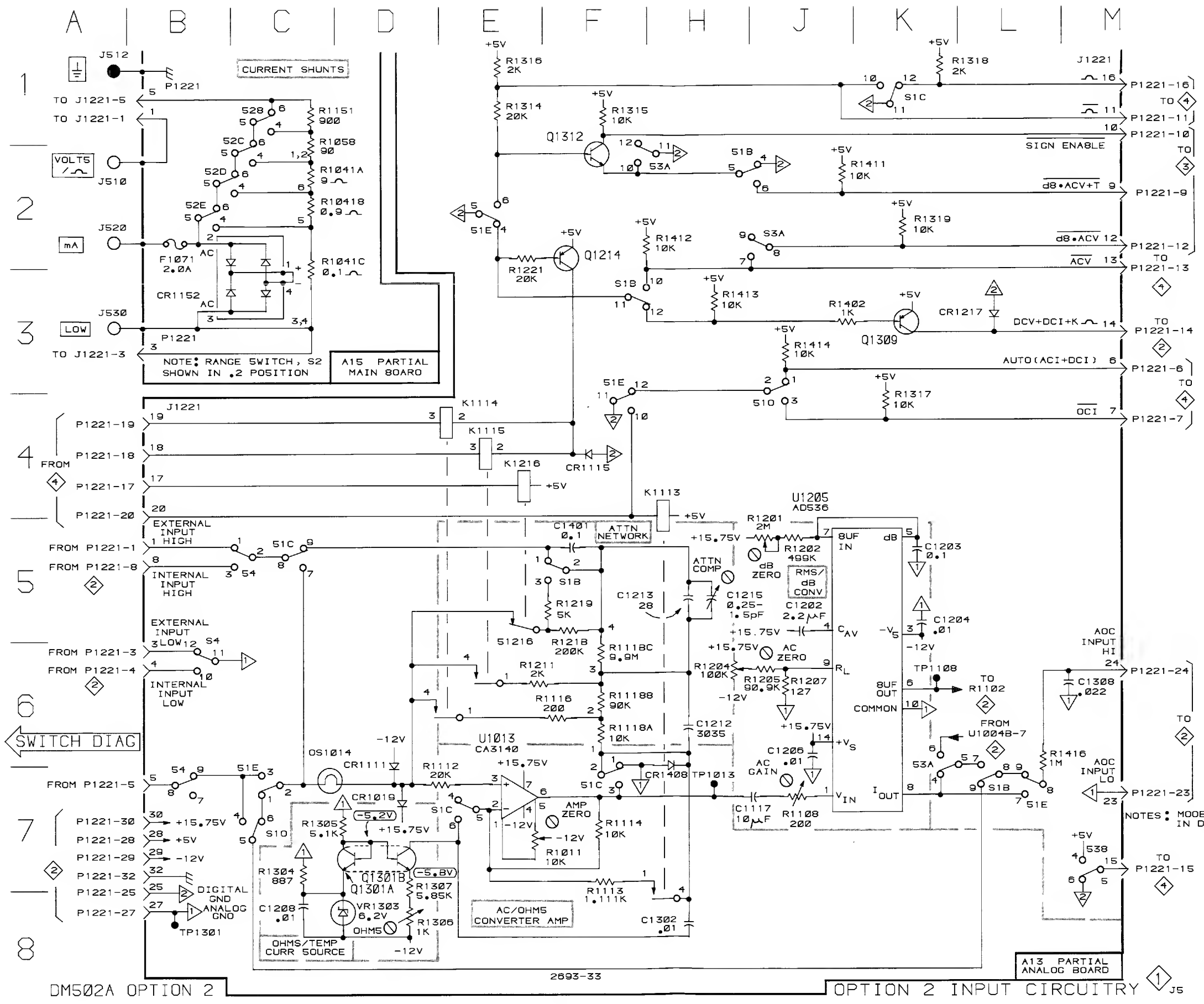

DM502A OPTION 2

2693-33

OPTION 2 INPUT CIRCUITRY

A13 PARTIAL ANALOG BOARD

REV A JAN 1980

NOTES: MOOE SWITCH, S1 IN DCV POSITION

Static Sensitive Devices
See Maintenance Section

COMPONENT NUMBER EXAMPLE

Component Number		
A23 A2 R1234		
Assembly Number	Subassembly Number (if used)	Schematic Circuit Number

Chassis-mounted components have no Assembly Number prefix—see end of Replaceable Electrical Parts List.

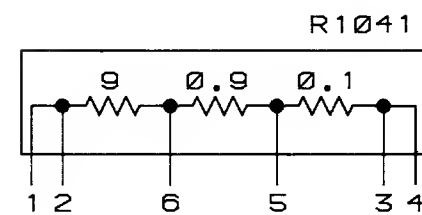
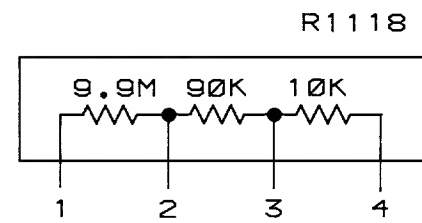
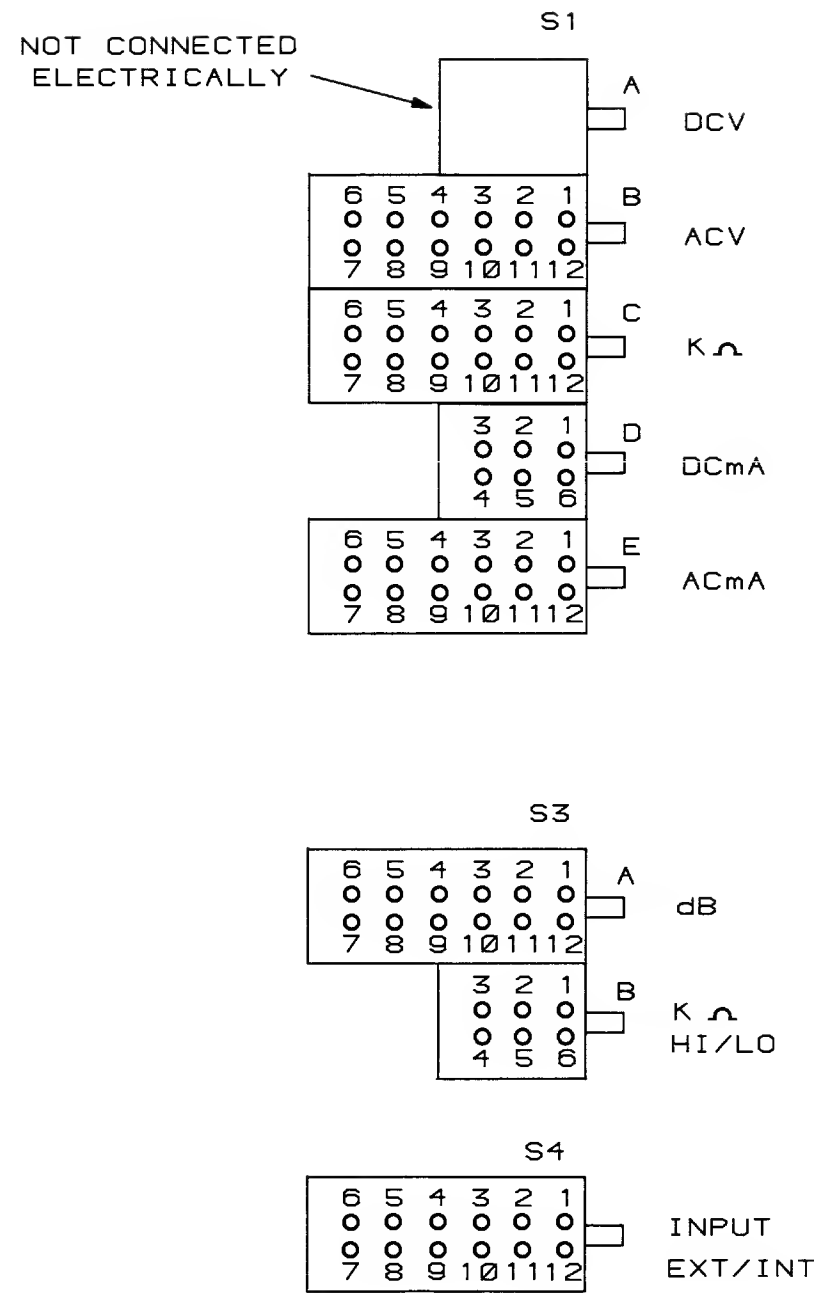

PARTS LOCATION

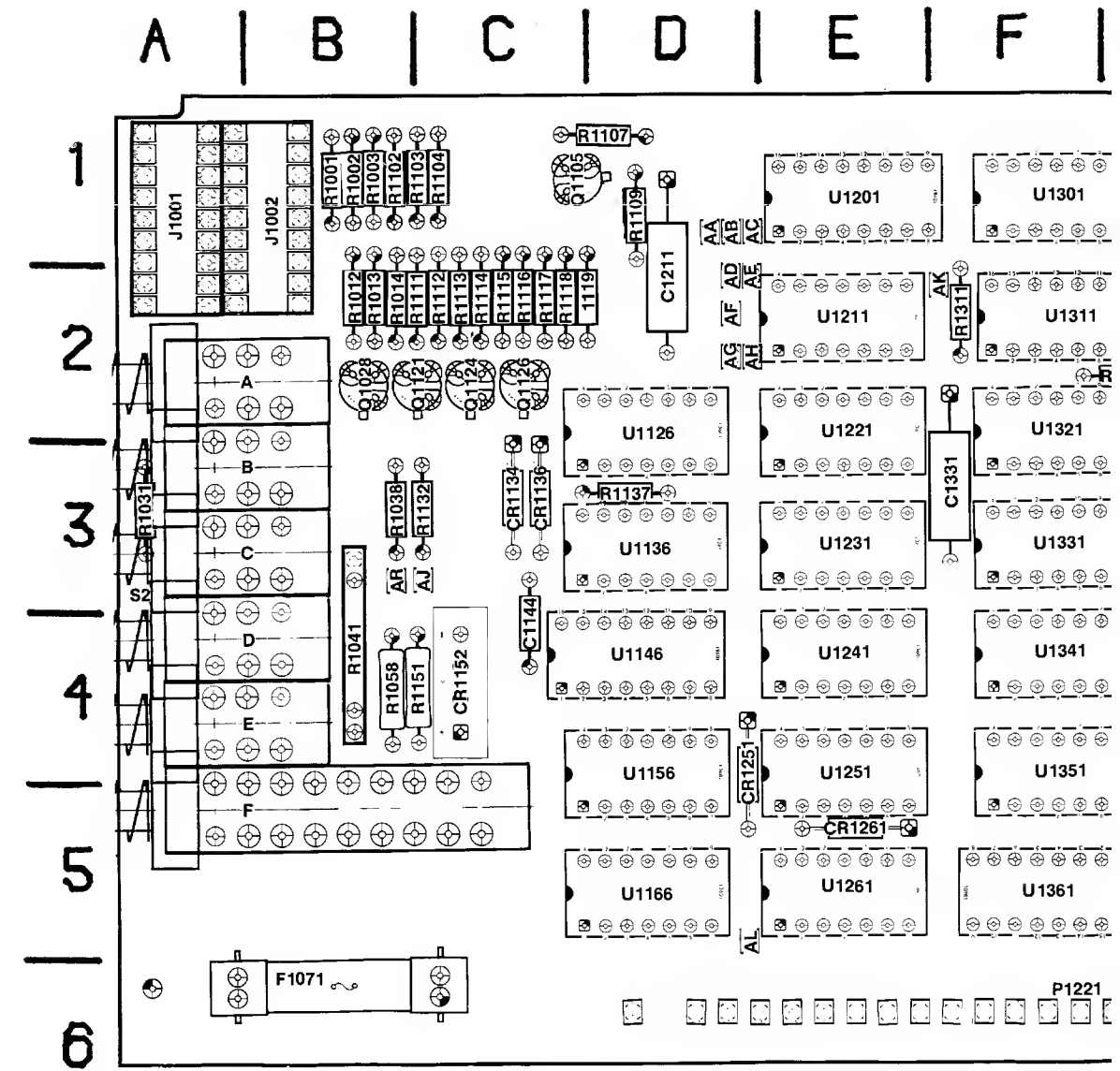
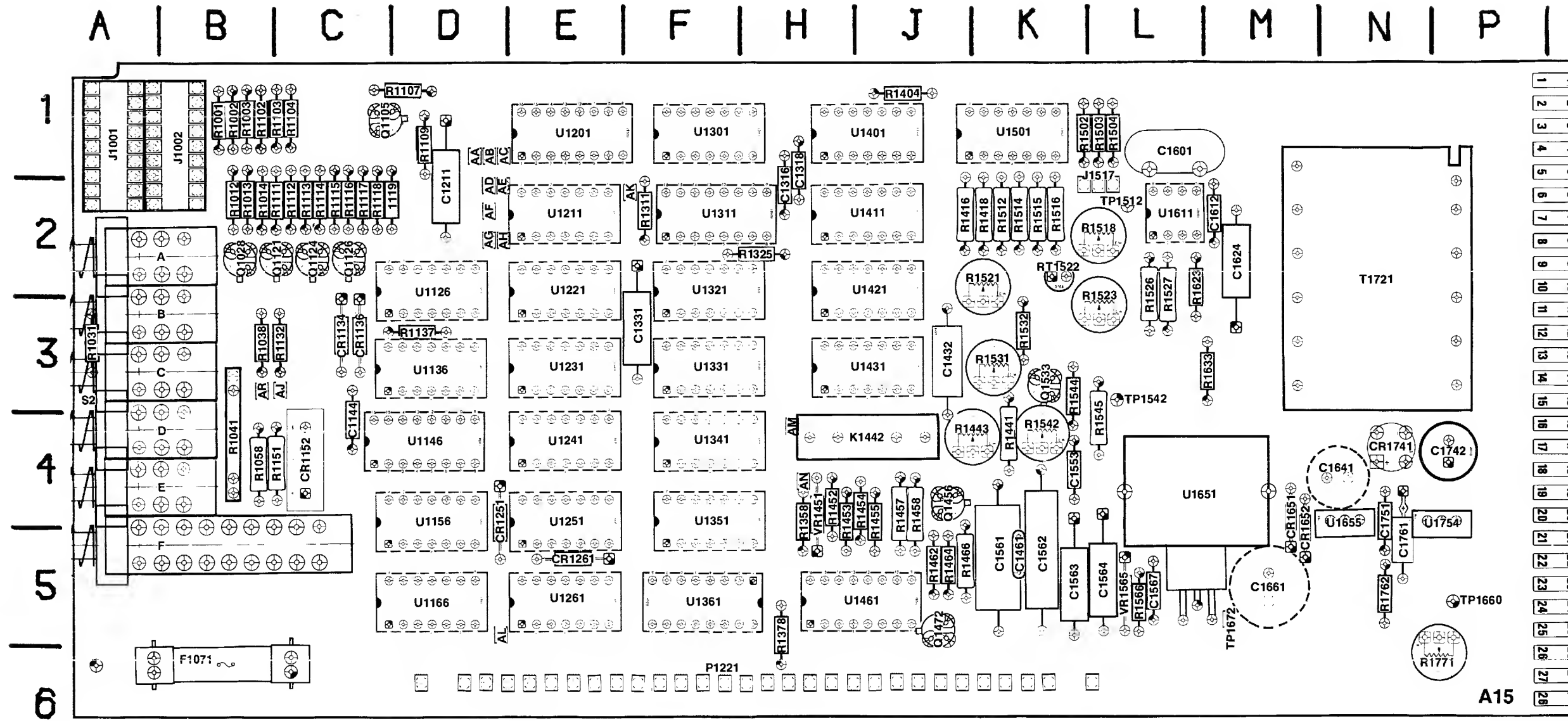

Fig. 8-15. M

PARTS LOCATION
MAIN BOARD (A15 ASSY)

PARTS LOCATION GRID



2693-23

Fig. 8-15. Main Board (A15).

⊗ Static Sensitive Devices
See Maintenance Section

COMPONENT NUMBER EXAMPLE

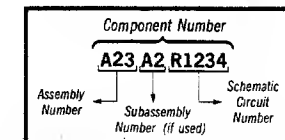

Chassis mounted components have no Assembly Number prefix—see end of Replaceable Electrical Parts List.

TION GRID

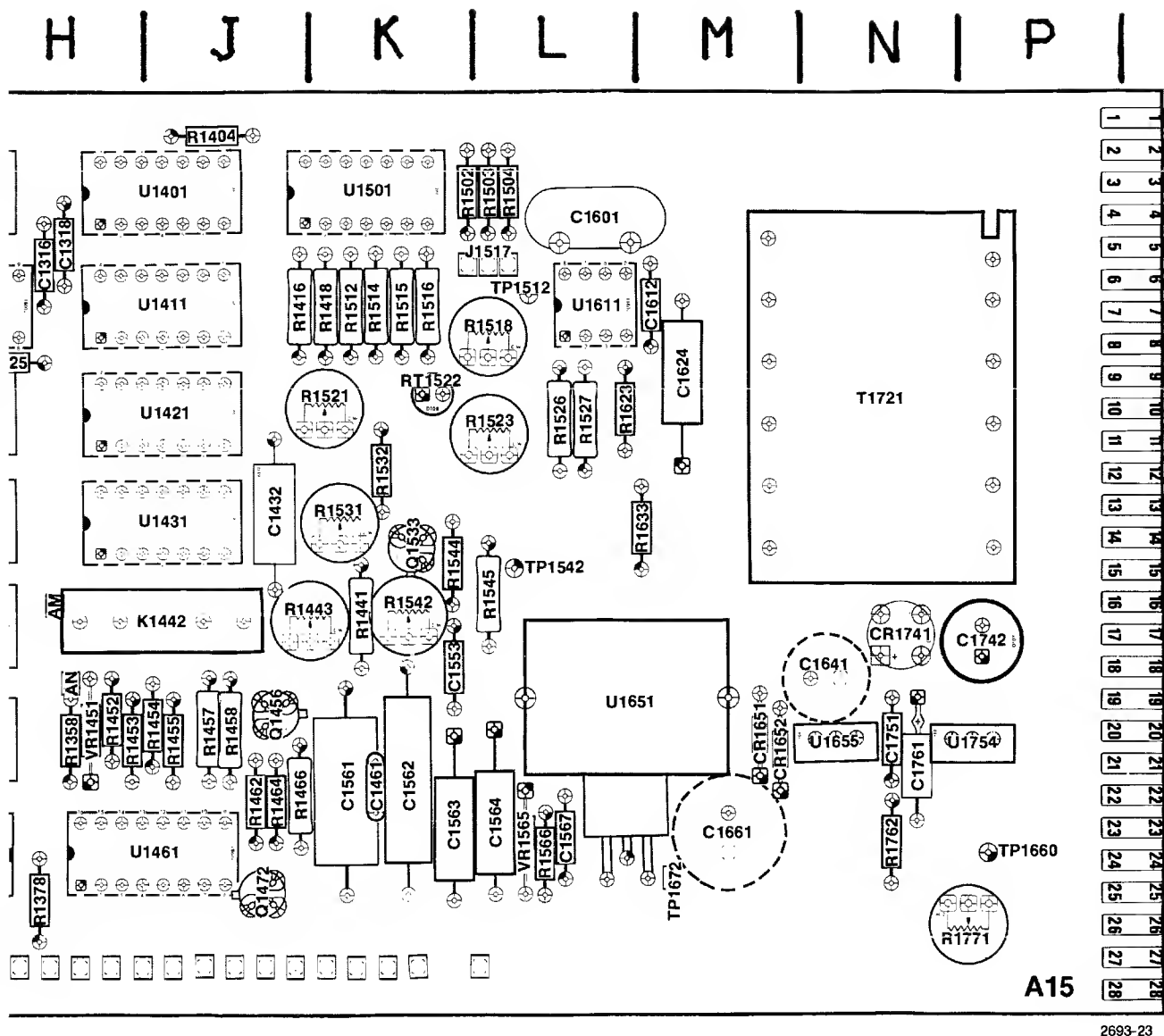

n Board (A15).

⊗ Static Sensitive Devices
See Maintenance Section

COMPONENT NUMBER EXAMPLE

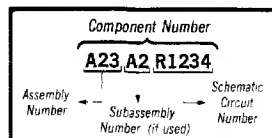

Chassis-mounted components have no Assembly Number prefix—see end of Replaceable Electrical Parts List

REV A JAN 1980

Table 8-3
COMPONENT
REFERENCE CHART

P/O A15 ASSY			A/D Converter dB Scaling, Pwr Supply		
Circuit Number	Schematic Location	Board Location	Circuit Number	Schematic Location	Board Location
C1432	E3	J3	R1464	C5	J5
C1461	D4	K5	R1466	D4	J5
C1553	C2	K4	R1502	J8	K1
C1561	D4	K5	R1503	J7	L1
C1562	D2	K5	R1504	J7	L1
C1563	C3	K5	R1512	L8	K2
C1564	D3	L5	R1514	J6	K2
C1567	F7	L5	R1515	J6	K2
C1641	D6	N4	R1516	J6	K2
C1661	D7	M5	R1518	L7	L2
C1742	D6	P4	R1521	J6	K3
C1751	F6	N5	R1531	H3	K3
C1761	F6	N5	R1532	C3	K3
			R1542	C2	K4
CR1651	C7	M5	R1544	B2	K4
CR1652	C7	M5	R1545	C3	L4
CR1741	C6	N4	R1566	D4	L5
			R1633	C2	M3
J1517	L6	L1	R1762	D6	N5
			R1771	D6	P6
K1442	F1	J4	RT1522	L7	K3
P1517	L6	L1	T1721	B6	N3
Q1456	C5	J5	TP1542	F6	L4
Q1472	C5	J6	TP1660	L6	P6
Q1533	B2	K4	TP1672	F7	M6
R1358	F2	H5	U1401A	J7	J1
R1378	C4	H6	U1401B	J7	J1
R1416	J6	J2	U1401C	J8	J1
R1418	L7	K2	U1461	E5	J5
R1441	H2	K4	U1501	K6	K1
R1443	H3	K4	U1651	D7	L5
R1452	B5	H5	U1655	D6	N5
R1453	E3	H5	U1754	D6	P5
R1454	D2	J5			
R1455	F3	J5			
R1457	E2	J5	VR1451	C3	H5
R1458	H3	J5	VR1565	C3	L5
R1462	C5	J5			

P/O A15 ASSY also shown on ① ③ ④

P/O A13 ASSY Refer to Fig. 8-14			A/D Converter dB Scaling, Pwr Supply		
Circuit Number	Schematic Location	Board Location	Circuit Number	Schematic Location	Board Location
CR1021	L3	A5	R1028	L1	C5
CR1027	L2	C5	R1102	J4	C2
			R1105	K4	C2
R1012	K2	A3	R1107	K4	D2
R1013	J3	A4	R1121	M1	C5
R1014	K2	A4	R1122	L2	C5
R1015	K3	A4			
R1016	J2	B4	U1004B	K4	B2
R1017	J2	B4	U1015	J1	B4
R1018	K2	B4	U1025A	L2	B5
R1022	L2	A5	U1025B	L1	B5
R1023	K1	B5			
R1024	K3	B5			
R1026	K1	B5			

P/O A13 ASSY also shown on ①

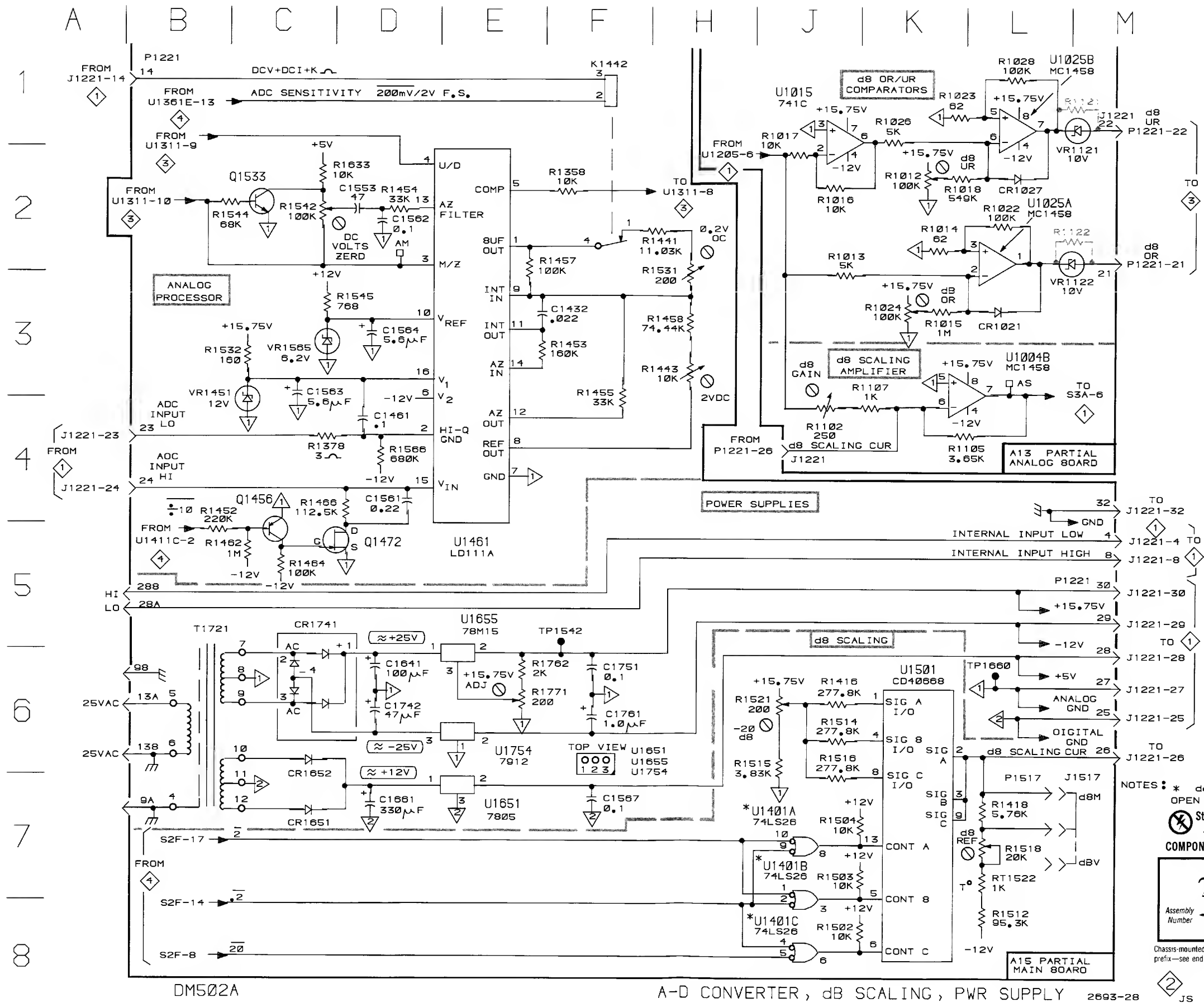

DM502A

A-D CONVERTER, dB SCALING, PWR SUPPLY 2693-28 JS

NOTES: * denotes OPEN COLLECTOR
 Static Sensitive Devices See Maintenance Section
COMPONENT NUMBER EXAMPLE

Component Number		
A23 A2 R1234		
Assembly Number	Subassembly Number (if used)	Schematic Circuit Number

Chassis-mounted components have no Assembly Number prefix—see end of Replaceable Electrical Parts List.

PARTS LOCATION GRID

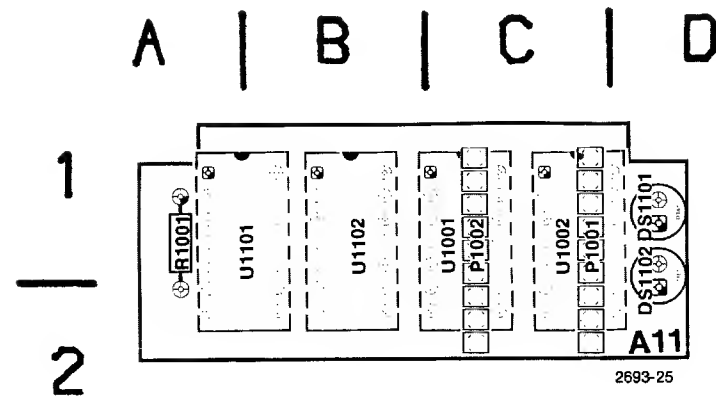
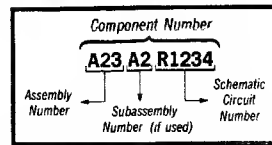

Fig. 8-16. Display Board (A11).

Static Sensitive Devices
See Maintenance Section

COMPONENT NUMBER EXAMPLE



Chassis mounted components have no Assembly Number prefix—see end of Replaceable Electrical Parts List

Table 8-4 COMPONENT REFERENCE CHART

P/O A15 ASSY Refer to Fig. 8-15			Display & Logic Circuitry		
Circuit Number	Schematic Location	Board Location	Circuit Number	Schematic Location	Board Location
C1316	C4	H2	R1116	F4	C2
C1318	C4	H2	R1118	E4	C2
C1601	C6	L1	R1119	L2	C2
C1612	B5	M2	R1132	M4	B3
C1624	A6	M2	R1523	A7	L3
			R1526	B7	L3
J1001	H7	A1	R1527	C6	L3
J1002	H5	B1	R1623	A6	L3
Q1028	H4	B2	TP1512	C5	L2
Q1105	E5	D1			
Q1121	L4	B2	U1136D	J3	D3
Q1124	K4	C2	U1201	E8	E1
Q1126	F4	C2	U1211A	K4	E2
			U1211B	F4	E2
R1001	F7	B1	U1211C	E4	E2
R1002	H8	B1	U1211D	E4	E2
R1003	H7	B1	U1211E	D6	E2
R1012	E6	B2	U1221A	K2	E2
R1013	F8	B2	U1221D	J3	E2
R1014	F4	B2	U1231C	E1	E3
R1031	E6	A3	U1301A	H3	F1
R1038	M4	B3	U1311	C3	F2
R1102	H8	B1	U1321	L2	F2
R1103	F7	C1	U1331D	E2	F3
R1104	H7	C1	U1361C	J2	F5
R1107	D5	D1	U1361F	D6	F5
R1111	E4	B2	U1421A	F1	J3
R1112	K4	C2	U1431A	F2	J3
R1113	K4	C2	U1431B	F2	J3
R1114	J4	C2	U1431C	H2	J3
R1115	J4	C2	U1611	B5	L2

P/O A15 ASSY also shown on

A11 ASSY			Display & Logic Circuitry		
DS1101	M6	D1	U1001	F5	C1
DS1102	M5	D2	U1002	H5	C1
P1001	H6	C1	U1101	J5	A1
P1002	H5	C1	U1102	L5	B1
R1001	F6	A1			

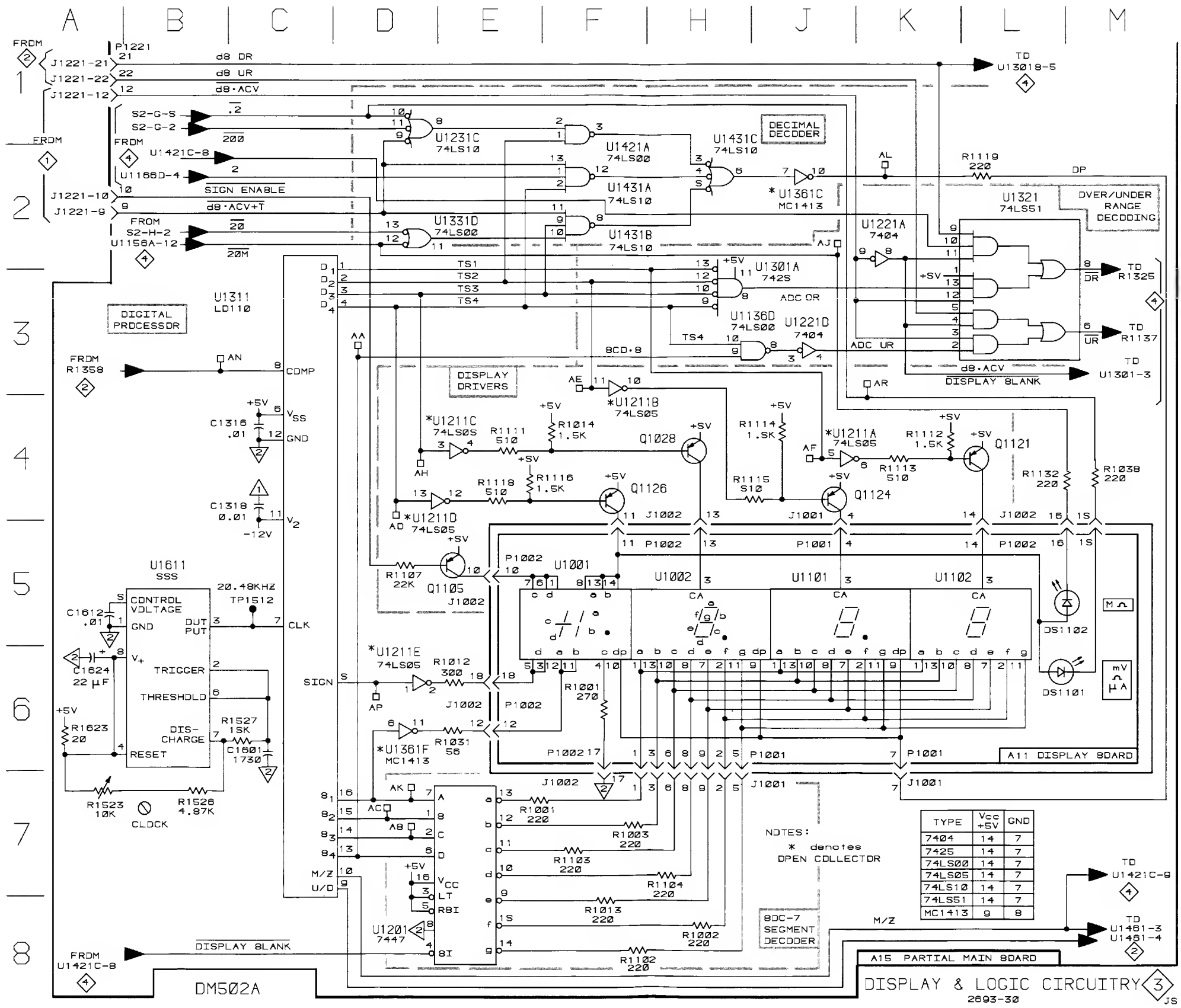

FRDM
FRDM
FRDM
FRDM
FRDM
FRDM
FRDM
FRDM

A | B | C | D | E | F | H | J | K | L | M

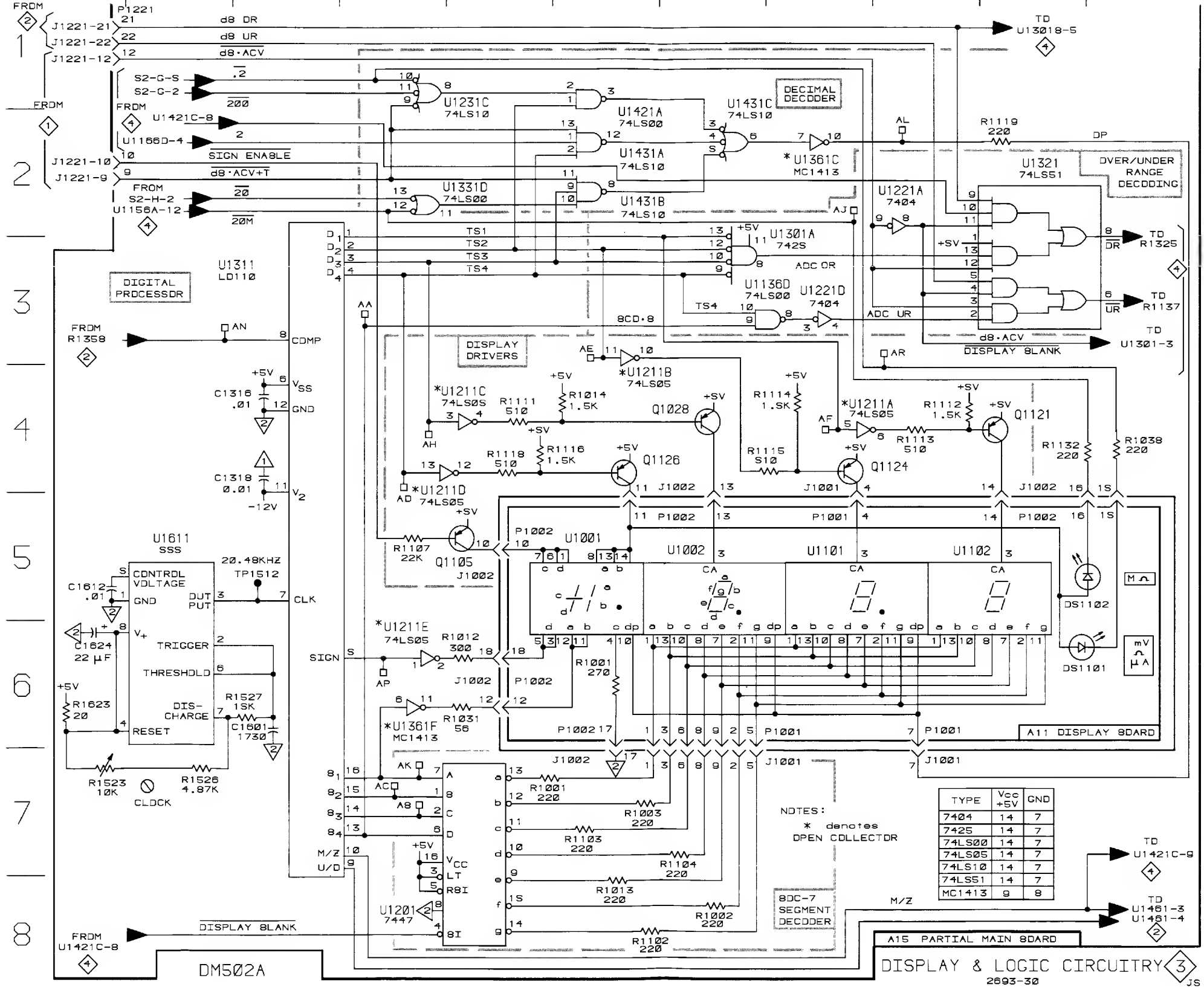

NOTES:
* denotes OPEN COLLECTOR

TYPE	Vcc +5V	GND
7404	14	7
7425	14	7
74LS00	14	7
74LS05	14	7
74LS10	14	7
74LS51	14	7
MC1413	9	8

Static Sensitive Devices
See Maintenance Section

COMPONENT NUMBER EXAMPLE

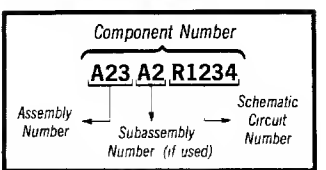



Chassis-mounted components have no Assembly Number prefix—see end of Replaceable Electrical Parts List.

DM502A
A15 PARTIAL MAIN BOARD
DISPLAY & LOGIC CIRCUITRY
2693-30

**Table 8-5
COMPONENT
REFERENCE
CHART**

P/O A15 ASSY Refer to Fig. 8-15			Range Logic 		
Circuit Number	Schematic Location	Board Location	Circuit Number	Schematic Location	Board Location
C1144	B5	C4	U1166C	F4	D5
C1211	B5	D2	U1166D	F5	D5
C1331	B4	F3	U1166E	F6	D5
			U1166F	J7	D5
CR1134	C5	C3	U1211F	J3	E2
CR1136	C5	C3	U1221B	C4	E2
CR1251	L8	D5	U1221C	C8	E2
CR1261	K8	E5	U1221E	E1	E2
			U1221F	K1	E2
R1109	B6	D1	U1231A	K5	E3
R1117	B6	C2	U1231B	L6	E3
R1137	B5	D3	U1241A	K5	E4
R1311	J3	F2	U1241B	K4	E4
R1325	B4	F2	U1241C	K6	E4
R1404	D2	J1	U1241D	K6	E4
			U1251A	L7	E5
S2-A	E6	A2	U1251B	L5	E5
S2-B	E5	A3	U1261A	K8	E5
S2-C	E5	A3	U1261B	K7	E5
S2-D	E4	A4	U1261C	K7	E5
S2-E	E3	A4	U1261D	K6	E5
S2-F	E3	A5	U1301B	D7	F1
S2-F	E4	A5	U1331A	K2	F3
S2-F	E5	A5	U1331B	H2	F3
S2-F	E5	A5	U1331C	K2	F3
S2-F	E6	A5	U1341A	L4	F4
S2-F	B7	A5	U1341B	L2	F4
			U1351A	K4	F5
U1126A	H1	D3	U1351B	K4	F5
U1126B	H1	D3	U1351C	K3	F5
U1126C	C7	D3	U1351D	K2	F5
U1126D	C6	D3	U1361A	L2	F5
U1136A	C5	D3	U1361B	L4	F5
U1136B	F2	D3	U1361C	L6	F5
U1136C	E2	D3	U1361D	L7	F5
U1146	D6	D4	U1361E	L5	F5
U1156A	E3	D5	U1401D	D2	J1
U1156B	E3	D5	U1411A	E7	J2
U1156C	E4	D5	U1411B	F7	J2
U1156D	E4	D5	U1411C	H7	J2
U1156E	E5	D5	U1421B	C2	J3
U1156F	E6	D5	U1421C	F8	J3
U1166A	F3	D5	U1421D	D8	J3
U1166B	F4	D5			

P/O A15 ASSY also shown on   

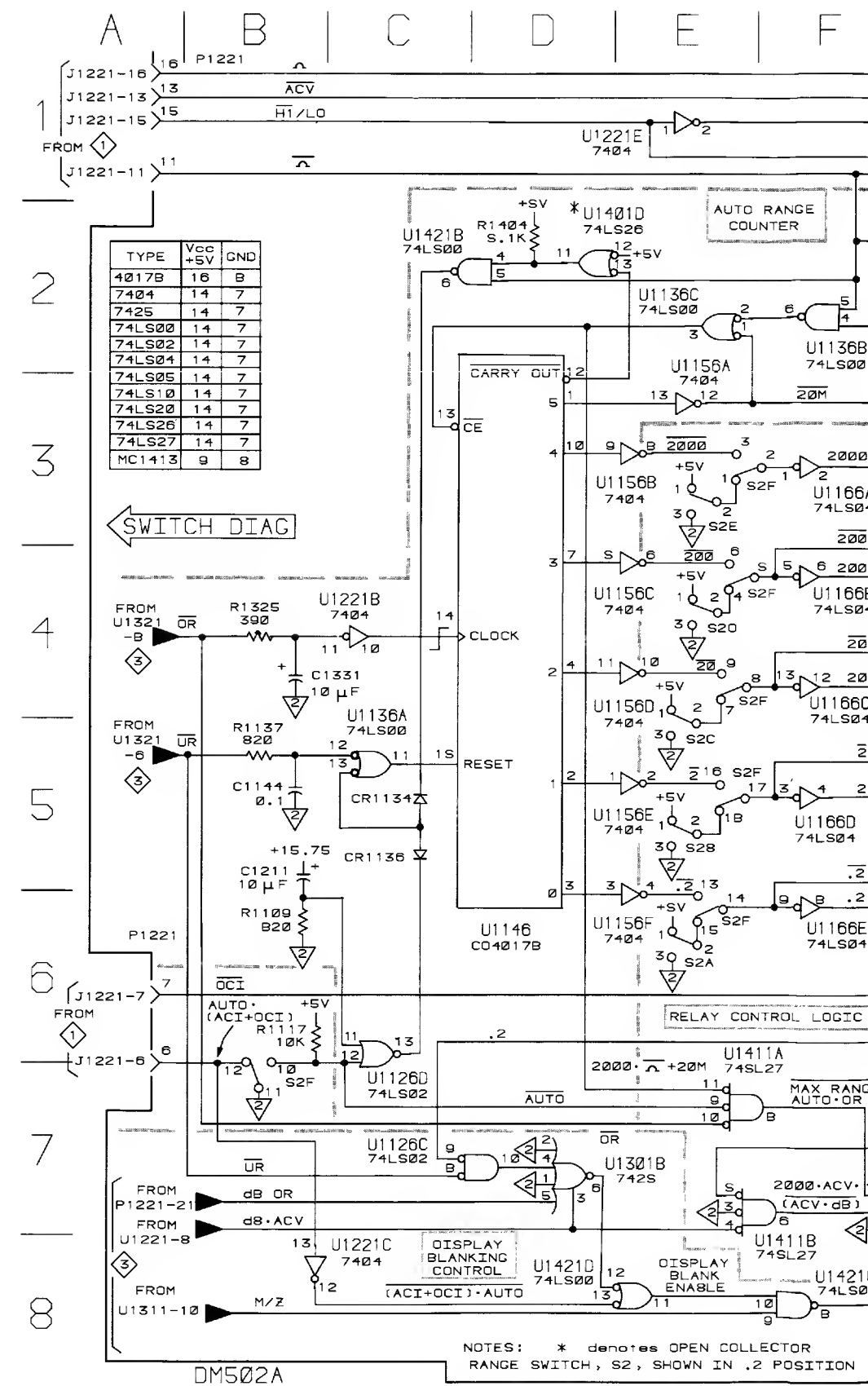
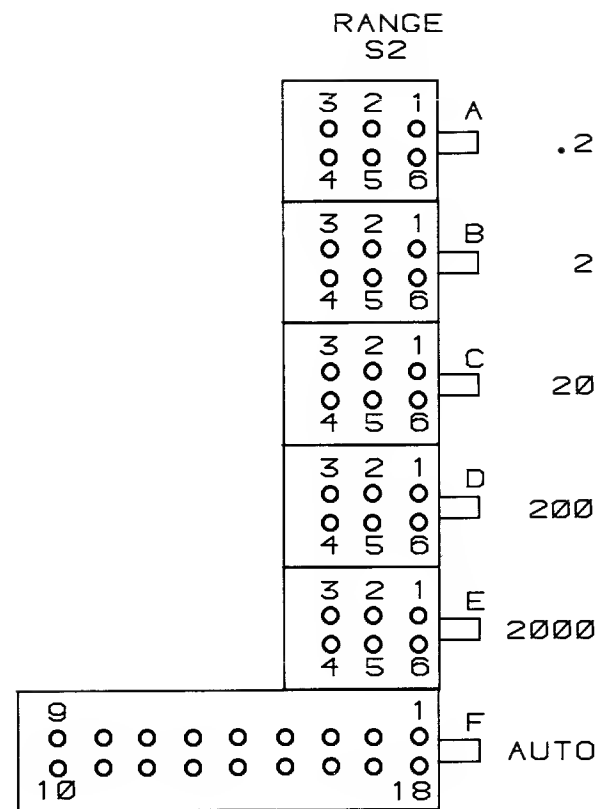

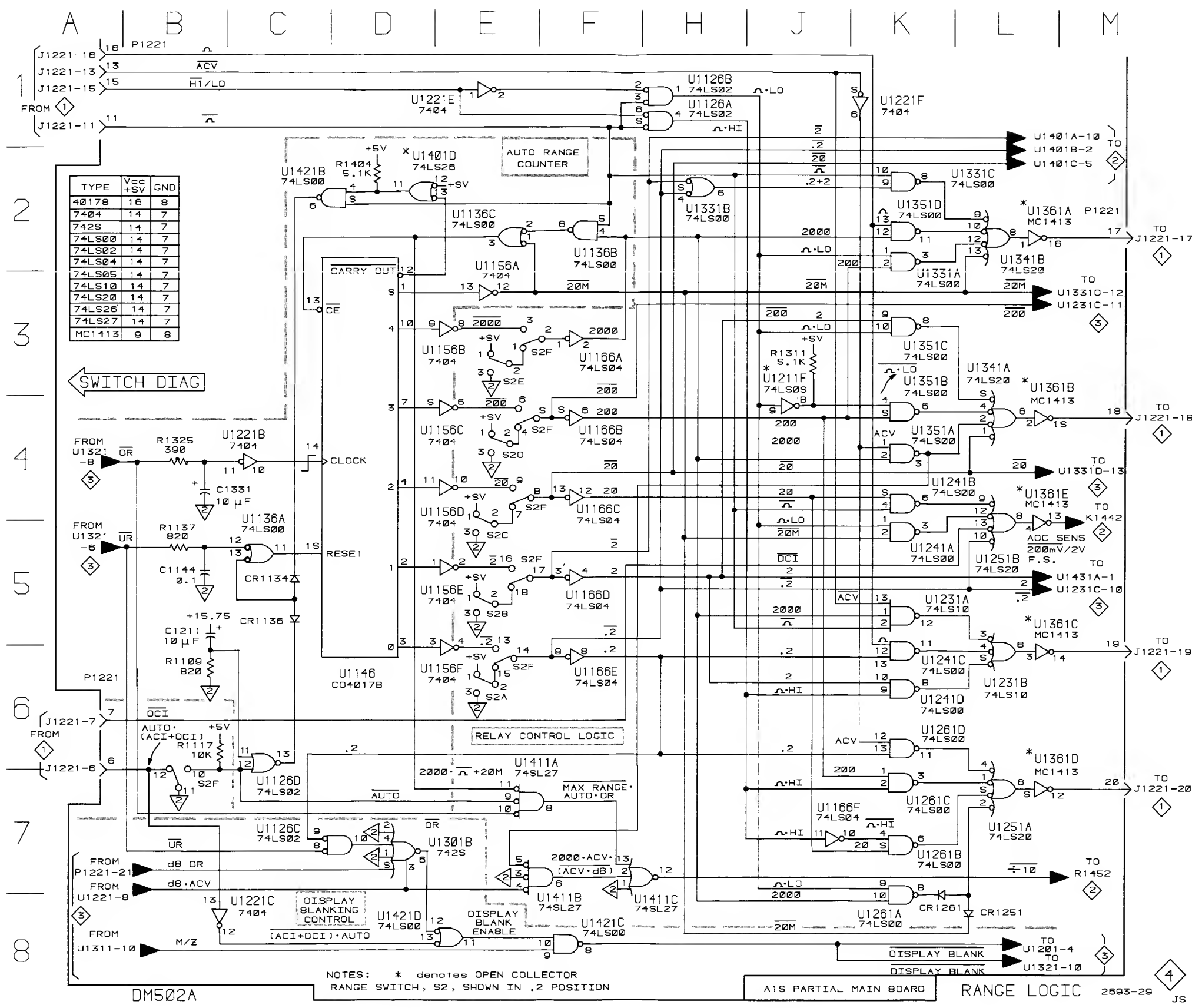

TYPE	VCC +5V	GND
4017B	16	8
7404	14	7
742S	14	7
74LS00	14	7
74LS02	14	7
74LS04	14	7
74LS05	14	7
74LS10	14	7
74LS20	14	7
74LS26	14	7
74LS27	14	7
MC1413	9	8

SWITCH DIAG

NOTES: * denotes OPEN COLLECTOR RANGE SWITCH, S2, SHOWN IN .2 POSITION

Static Sensitive Devices See Maintenance Section

COMPONENT NUMBER EXAMPLE

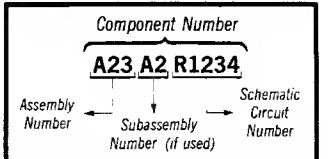

Chassis-mounted components have no Assembly Number prefix—see end of Replaceable Electrical Parts List.

REPLACEABLE MECHANICAL PARTS

PARTS ORDERING INFORMATION

Replacement parts are available from or through your local Tektronix, Inc. Field Office or representative.

Changes to Tektronix instruments are sometimes made to accommodate improved components as they become available, and to give you the benefit of the latest circuit improvements developed in our engineering department. It is therefore important, when ordering parts, to include the following information in your order: Part number, instrument type or number, serial number, and modification number if applicable.

If a part you have ordered has been replaced with a new or improved part, your local Tektronix, Inc. Field Office or representative will contact you concerning any change in part number.

Change information, if any, is located at the rear of this manual.

SPECIAL NOTES AND SYMBOLS

X000 Part first added at this serial number
00X Part removed after this serial number

FIGURE AND INDEX NUMBERS

Items in this section are referenced by figure and index numbers to the illustrations.

INDENTATION SYSTEM

This mechanical parts list is indented to indicate item relationships. Following is an example of the indentation system used in the description column.

```

1 2 3 4 5           Name & Description
Assembly and/or Component
Attaching parts for Assembly and/or Component
  --- * ---
Detail Part of Assembly and/or Component
Attaching parts for Detail Part
  --- * ---
Parts of Detail Part
Attaching parts for Parts of Detail Part
  --- * ---

```

Attaching Parts always appear in the same indentation as the item it mounts, while the detail parts are indented to the right. Indented items are part of, and included with, the next higher indentation. The separation symbol --- * --- indicates the end of attaching parts.

Attaching parts must be purchased separately, unless otherwise specified.

ITEM NAME

In the Parts List, an Item Name is separated from the description by a colon (:). Because of space limitations, an Item Name may sometimes appear as incomplete. For further Item Name identification, the U.S. Federal Cataloging Handbook H6-1 can be utilized where possible.

ABBREVIATIONS

"	INCH	ELECTRN	ELECTRON	IN	INCH	SE	SINGLE END
#	NUMBER SIZE	ELEC	ELECTRICAL	INCAND	INCANDESCENT	SECT	SECTION
ACTR	ACTUATOR	ELECTLT	ELECTROLYTIC	INSUL	INSULATOR	SEMICON	SEMICONDUCTOR
ADPTR	ADAPTER	ELEM	ELEMENT	INTL	INTERNAL	SHLD	SHIELD
ALIGN	ALIGNMENT	EPL	ELECTRICAL PARTS LIST	LPHLDR	LAMPHOLDER	SHLDR	SHOULDERED
AL	ALUMINUM	EOPT	EQUIPMENT	MACH	MACHINE	SKT	SOCKET
ASSEM	ASSEMBLED	EXT	EXTERNAL	MECH	MECHANICAL	SL	SLIDE
ASSY	ASSEMBLY	FIL	FILLISTER HEAD	MTG	MOUNTING	SLFLKG	SELF-LOCKING
ATTEN	ATTENUATOR	FLEX	FLEXIBLE	NIP	NIPPLE	SLVG	SLEEVING
AWG	AMERICAN WIRE GAGE	FLH	FLAT HEAD	NON WIRE	NOT WIRE WOUND	SFR	SPRING
BD	BOARD	FLTR	FILTER	OB	ORDER BY DESCRIPTION	SQ	SQUARE
BRKT	BRACKET	FR	FRAME or FRONT	OD	OUTSIDE DIAMETER	SST	STAINLESS STEEL
BRS	BRASS	FSTNR	FASTENER	OVH	OVAL HEAD	STL	STEEL
BRZ	BRONZE	FT	FOOT	PH BRZ	PHOSPHOR BRONZE	SW	SWITCH
BSHG	BUSHING	FXD	FIXED	PL	PLAIN or PLATE	T	TUBE
CAB	CABINET	GSKT	GASKET	PLSTC	PLASTIC	TERM	TERMINAL
CAP	CAPACITOR	HDL	HANDLE	PN	PART NUMBER	THD	THREAD
CER	CERAMIC	HEX	HEXAGON	PNH	PAN HEAD	THK	THICK
CHAS	CHASSIS	HEX HD	HEXAGONAL HEAD	PWR	POWER	TNSN	TENSION
CKT	CIRCUIT	HEX SOC	HEXAGONAL SOCKET	RCPT	RECEPTACLE	TPG	TAPPING
COMP	COMPOSITION	HLCP	HELICAL COMPRESSION	RES	RESISTOR	TRH	TRUSS HEAD
CONN	CONNECTOR	HLEXT	HELICAL EXTENSION	RGD	RIGID	V	VOLTAGE
COV	COVER	HV	HIGH VOLTAGE	RLF	RELIEF	VAR	VARIABLE
CPLG	COUPLING	IC	INTEGRATED CIRCUIT	RTNR	RETAINER	W/	WITH
CRT	CATHODE RAY TUBE	ID	INSIDE DIAMETER	SCH	SOCKET HEAD	WSHR	WASHER
DEG	DEGREE	IDNT	IDENTIFICATION	SCOPE	OSCILLOSCOPE	XFMR	TRANSFORMER
DWR	DRAWER	IMPLR	IMPELLER	SCR	SCREW	XSTR	TRANSISTOR

CROSS INDEX—MFR. CODE NUMBER TO MANUFACTURER

Mfr. Code	Manufacturer	Address	City, State, Zip
83013	LEMO SA ELEKTROTECHNIQUE	RTE DE LAUSANNE MORGES	SWITZERLAND
000BH	FAB-TEK	17 SUGAR HOLLOW ROAD	DANBURY, CT 06810
00779	AMP, INC.	P O BOX 3608	HARRISBURG, PA 17105
01295	TEXAS INSTRUMENTS, INC., SEMICONDUCTOR GROUP	P O BOX 5012, 13500 N CENTRAL EXPRESSWAY	DALLAS, TX 75222
22526	BERG ELECTRONICS, INC.	YOUK EXPRESSWAY	NEW CUMBERLAND, PA 17070
55210	GETTIG ENG. AND MFG. COMPANY	PO BOX 85, OFF ROUTE 45	SPRING MILLS, PA 16875
73743	FISCHER SPECIAL MFG. CO.	446 MORGAN ST.	CINCINNATI, OH 45206
78189	ILLINOIS TOOL WORKS, INC. SHAKEPROOF DIVISION	ST. CHARLES ROAD	ELGIN, IL 60120
80009	TEKTRONIX, INC.	P O BOX 500	BEAVERTON, OR 97077
82647	TEXAS INSTRUMENTS, INC., CONTROL PRODUCTS DIV.	34 FOREST ST.	ATTLEBORO, MA 02703
83385	CENTRAL SCREW CO.	2530 CRESCENT DR.	BROADVIEW, IL 60153
86928	SEASTROM MFG. COMPANY, INC.	701 SONORA AVENUE	GLENDALE, CA 91201
87308	N. L. INDUSTRIES, INC., SOUTHERN SCREW DIV.	P. O. BOX 1360	STATESVILLE, NC 28677
93907	CAMCAR SCREW AND MFG. CO.	600 18TH AVE.	ROCKFORD, IL 61101

Replaceable Mechanical Parts—DM 502A

Fig. & Index No.	Tektronix Part No.	Serial/Model No. Eff Dscont	Qty	1	2	3	4	5	Name & Description	Mfr Code	Mfr Part Number
1-1	337-1399-07		2						SHIELD,ELEC:SIDE	80009	337-1399-07
-2	334-3504-00		1						MARKER,IDENT:DIGITAL MULTIMETER AUTO	80009	334-3504-00
-3	378-2030-02		1						ENS,LED DSPL:RED W/MARKINGS	80009	378-2030-02
-4	366-1512-00		2						PUSH BUTTON:GRAY,0.18 SQ X 0.83 INCH LG	80009	366-1512-00
-5	366-1512-01		1						PUSH BUTTON:CHARCOAL GY,0.18 SQ X 0.8	80009	366-1512-01
-6	366-1559-05		1						PUSH BUTTON:CHARCOAL GRAY,0.18 SQ X 0.43	80009	366-1559-05
-7	366-1559-00		11						PUSH BUTTON:STL GY,0.18 SQ X 0.43	80009	366-1559-00
-8	220-0633-00		1						NUT,PLAIN,KNURL:0.25-28 X 0.25 INCH L,BRS	80009	220-0633-00
-9	355-0170-00		1						STUD,SHOULDERED:6-32 X 0.40 INCH LONG	80009	355-0170-00
-10	131-1652-00		1						CONN,RCPT,ELEC:'LEMO' TYPE,1MALE,1 FEMALE (STANDARD ONLY)	53013	RA0302
-11	366-1690-00		1						KNOB:LATCH	80009	366-1690-00
-12	105-0719-00		1						LATCH,RETAINING:PLUG-IN (ATTACHING PARTS)	80009	105-0719-00
-13	213-0113-00		1						SCR,TPG,THD FOR:2-32 X 0.312 INCH,PNH STL	93907	OBD
-14	105-0718-01		1						BAR,LATCH RLSE:	80009	105-0718-01
-15	211-0537-00		1						SCREW,MACHINE:6-32 X 0.375 INCH,TRH STL	83385	OBD
-16	136-0730-00		1						JACK,TIP:BLUE (ATTACHING PARTS)	80009	136-0730-00
-17	210-0465-00		1						NUT,PLAIN,HEX.:0.25-32 X 0.375 INCH BRS	73743	3095-402
-18	210-0223-00		1						TERMINAL,LUG:0.25 INCH DIA,SE	86928	A313-136
-19	210-0905-00		1						WASHER,FLAT:0.256 ID X 0.438 INCH OD,BRS	83385	OBD
-20	136-0498-00	B010100	1						JACK,TIP:BLACK	80009	136-0498-00
	136-0731-00	B020430	1						JACK,TIP:BLACK (ATTACHING PARTS)	80009	136-0731-00
-21	210-0465-00		1						NUT,PLAIN,HEX.:0.25-32 X 0.375 INCH BRS	73743	3095-402
-22	210-0223-00		1						TERMINAL,LUG:0.25 INCH DIA,SE	86928	A313-136
-23	210-0905-00		1						WASHER,FLAT:0.256 ID X 0.438 INCH OD,BRS	83385	OBD
-24	136-0497-00	B010100	1						JACK,TIP:RED	80009	136-0497-00
	136-0732-00	B020430	1						JACK,TIP:RED (ATTACHING PARTS)	80009	136-0732-00
-25	210-0465-00		1						NUT,PLAIN,HEX.:0.25-32 X 0.375 INCH BRS	73743	3095-402
-26	210-0223-00		1						TERMINAL,LUG:0.25 INCH DIA,SE	86928	A313-136
-27	210-0905-00		1						WASHER,FLAT:0.256 ID X 0.438 INCH OD,BRS	83385	OBD
-28	333-2530-00		1						PANEL,FRONT:	80009	333-2530-00
	333-2531-00		1						PANEL,FRONT: (OPTION 2 ONLY)	80009	333-2531-00
-29	386-4115-00		1						SUBPANEL,FRONT: (ATTACHING PARTS)	80009	386-4115-00
-30	213-0192-00	B010100	2						SCR,TPG,THD FOR:6-32 X 0.50 INCH,PNH STL	87308	OBD
	213-0789-00	B020430	2						SCREW,TPG,TF:6-32 X 0.375,TAPTITE,PNH	93907	OBD
-31	-----		1						CKT BOARD ASSY:DISPLAY(SEE A11 EPL)		
-32	131-1857-00		1						. TERM. SET,PIN:36/0.025 SQ PIN,ON 0.1 CTRS	22526	65500136
-33	131-1934-00		1						. TERM. SET,PIN:1 X 36,0.1 CTR,0.9 L	22526	65539-001
-34	337-2615-00		1						SHIELD,ELEC:CIRCUIT BOARD (ATTACHING PARTS)	80009	337-2615-00
-35	211-0007-00		3						SCREW,MACHINE:4-40 X 0.188 INCH,PNH STL	83385	OBD
-36	210-0004-00		1						WASHER,LOCK:#4 INTL,0.015THK,STL CD PL	78189	1204-00-00-0541C
-37	384-1292-00		3						EXTENSION SHAFT:2.417 INCH LONG,PLASTIC	80009	384-1292-00
-38	129-0463-00		3						SPACER,POST:0.188 HEX X 0.937"L,W/4-40 THD (ATTACHING PARTS)	80009	129-0463-00
-39	211-0116-00		3						SCR,ASSEM WSHR:4-40 X 0.312 INCH,PNH BRS	83385	OBD
-40	-----		1						CKT BOARD ASSY:ANALOG(SEE A13 EPL) (ATTACHING PARTS)		
-41	211-0116-00		4						SCR,ASSEM WSHR:4-40 X 0.312 INCH,PNH BRS	83385	OBD
-42	131-0608-00		2						. CKT BOARD ASSY INCLUDES:		
-43	136-0263-04		30						. TERMINAL,PIN:0.365 L X 0.25 PH,BRZ,GOLD PL	22526	47357
-44	136-0269-02		1						. SOCKET,PIN TERM:FOR 0.025 INCH SQUARE PIN	22526	48059
			1						. SOCKET,PLUG-IN:14 CONTACT,LOW CLEARANCE	01295	C95140

Replaceable Mechanical Parts—DM 502A

Fig. & Index No.	Tektronix Part No.	Serial/Model No. Eff Dscont	Qty	1	2	3	4	5	Name & Description	Mfr Code	Mfr Part Number
1-45	344-0154-00		2	.					CLIP,ELECTRICAL:FUSE,CKT BD MT	80009	344-0154-00
-46	214-0579-00		3	.					TERM,TEST POINT:BRS CD PL	80009	214-0579-00
-47	-----		1	.					SWITCH,PUSH:6 BTN,FUNCTION(SEE A13S1 EPL)		
	-----		1	.					SWITCH,PUSH:5 BTN,FUNCTION(SEE A13S1 EPL)		
	-----		-	.					(OPTION 2 ONLY)		
-48	361-0685-00		4	.					SPACER,SWITCH:0.365 INCH LONG	80009	361-0685-00
-49	-----		1	.					SWITCH,PUSH:1 BTN,INPUT(SEE A13S4 EPL)		
-50	-----		1	.					SWITCH,PUSH:2 BTN,LOW HI DB8SEE A13S3 EPL)		
-51	361-0573-00		10	.					SPACER,SLEEVE:0.234 L,BLACKPP	80009	361-0573-00
-52	129-0759-00		2	.					SPACER,POST:0.53 L,W/4-40 THRU THD (ATTACHING PARTS)	80009	129-0759-00
-53	211-0121-00		2	.					SCR,ASSEM WSHR:4-40 X 0.438 INCH,PNH BRS - - - * - - -	83385	OBD
-54	129-0759-00		2	.					SPACER,POST:0.53 L,W/4-40 THRU THD (ATTACHING PARTS)	80009	129-0759-00
-55	211-0116-00		2	.					SCR,ASSEM WSHR:4-40 X 0.312 INCH,PNH BRS - - - * - - -	83385	OBD
-56	-----		1	.					CKT BOARD ASSY:MAIN(SEE A15 EPL) (ATTACHING PARTS)		
-57	213-0146-00		2	.					SCR,TPG,THD FOR:6-20 X 0.313 INCH,PNH STL - - - * - - -	83385	OBD
	-----		-	.					CKT BOARD ASSY INCLUDES:		
-58	-----		1	.					TRANSFORMER:(SEE A15T1721 EPL)		
-59	-----		1	.					SWITCH,PUSH:(SEE A15S2 EPL)		
-60	361-0685-00		4	.					SPACER,SWITCH:0.365 INCH LONG	80009	361-0685-00
-61	131-0592-00		30	.					CONTACT,ELEC:0.885 INCH LONG	22526	47353
-62	136-0631-00		2	.					SOCKET,PLUG-IN:9 PIN FEMALE	00779	1-380949-9
-63	131-0608-00		3	.					TERMINAL,PIN:0.365 L X 0.25 PH,BRZ,GOLD PL	22526	47357
-64	131-0993-00		1	.					BUS,CONDUCTOR:2 WIRE BLACK	00779	530153-2
-65	214-2518-00		1	.					HEAT SINK,XSTR:TO-220 OR TO-202	000BH	106B-B-HT
-66	214-0579-00		3	.					TERM,TEST POINT:BRS CD PL	80009	214-0579-00
-67	131-0566-00		1	.					LINK,TERM.CONNE:0.086 DIA X 2.375 INCH L	55210	L-2007-1
-68	136-0260-02		5	.					SOCKET,PLUG-IN:16 CONTACT,LOW CLEARANCE	82647	C9316-18
-69	136-0269-02		1	.					SOCKET,PLUG-IN:14 CONTACT,LOW CLEARANCE	01295	C95140
-70	344-0154-00		2	.					CLIP,ELECTRICAL:FUSE,CKT BD MT	80009	344-0154-00
-71	426-0724-19		1	.					FR SECT,PLUG-IN:BOTTOM	80009	426-0724-19
	426-0724-04	B010100 B020429	1	.					FR SECT,PLUG-IN:BOTTOM	80009	426-0724-04
	-----		-	.					(OPTION 2 ONLY)		
	426-0724-19	B020430	1	.					FR SECT,PLUG-IN:BOTTOM	80009	426-0724-19
	-----		-	.					(OPTION 2 ONLY)		
-72	386-3657-01		2	.					SUPPORT,PLUG IN:	93907	OBD
-73	210-1270-00		2	.					WASHER,FLAT:0.141 ID X 0.04 THK,AL	80009	210-1270-00
-74	426-1515-00		1	.					FR SECT,PLUG-IN:TOP	80009	426-1515-00
-75	214-1061-00		1	.					SPRING,GROUND:FLAT	80009	214-1061-00
	198-4199-00		1	.					WIRE SET,ELEC:	80009	198-4199-00
-76	131-0707-00		2	.					CONNECTOR,TERM.:22-26 AWG,BRS& CU BE GOLD	22526	47439
-77	352-0161-03		1	.					CONN BODY,PL,EL:3 WIRE ORANGE	80009	352-0161-03

Fig. & Index No.	Tektronix Part No.	Serial/Model No. Eff Dscont	Qty	1	2	3	4	5	Name & Description	Mfr Code	Mfr Part Number
STANDARD ACCESSORIES											
-1	070-2693-00		1						MANUAL, TECH: INSTRUCTION	80009	070-2693-00
-2	010-6601-01		1						PROBE, TEMP:	80009	010-6601-01
-3	003-0120-00		1						LEAD, TEST:	80009	003-0120-00

